

Innovative Technology

Individual Solutions

Intensive Support

**Our Ideas,
Your Success**

Product Summary for Buses and Coaches.

Innovative Technology meets Modern Design.



***Ideas today for
the cars of tomorrow***



DIVO 3.5 GT from Hispano

Freedom without adventure.

Mobility without adventure: A bus is only successful if the overall quality is right. Reassuring, then, if Hella quality comes along on the trip. Modern lighting technologies as well as integrated electric and electronic components at a quality level that has been setting standards for decades.

Brand character without adventure: A bus will only be a bestseller if it's design is right, too. The modular front and rear systems from Hella give bus designers unique freedom – highly efficiently, even for small series.

Innovative depth. Modular concepts. Technological leadership.

Hella has earned itself a leading global position through diligence, creativity and top-quality precision. For over one hundred years. Hella and modern bus production – a long-term successful partnership.

- More safety through innovations in lighting technology: e.g. Xenon and LED.
- More economy thanks to integrated electrics and electronics components.
- More equipment versions, more brand-typical features and more trendsetting: e.g. through an extraordinary depth of product range and modular systems.
- More safety in production and in use: e.g. through OEM quality, through synergies from our developments for the international automotive industry and zero-fault quality management.



Local Hella support.

We do not only see ourselves as top-quality suppliers, but rather as development partners. If required, our developers and engineers can work with your teams on site to prepare optimum solutions. This speeds up processes and prepares the way for new standards. More technological freedom, more styling freedom, more room for rationalisation: That is Hella.

We wish you a successful future.



Contents

Introduction

2	Freedom without adventure
4 – 5	LED technology: Lots of possibilities
6 – 9	LED indicators and the patented failure check
10	Xenon and Bi-Xenon®
11 – 12	Module headlights, customized vehicle design

Frontlighting

13	Modular frontlighting system
14	DynaView®
15	Daytime running light
16 – 18	90 mm headlights
19	50 mm headlights
20	Lens cleaning systems
21	Ultrasonic headlight range adjustment
22 – 25	Auxiliary frontlighting

Clearance lighting

26 – 27	Side marker lights, auxiliary indicators
---------	--



Rear lighting

28	Modular rear lighting system
29 – 40	Single and multi-functional lights
40	Reflectors, licence plate light
41	Safety stop lights

Interior lighting

42 – 51	Interior lighting
---------	-------------------

Electrics/Electronics

52	Electronic components
	Rain / light / sensors
53	Rear view camera
54 – 55	Micro-switches, rocker switches
56	Mirror range
57	Relays
58 – 61	Flasher units, horns, sockets, plugs
62	Trailer connection device
63	Voltage reduction and load compensation devices



LED technology: More safety, more economy, more design options.

More safety.

LED lights stand out due to their particularly fast switch-on times. Milliseconds on a stopwatch can mean quite a few yards on the motorway. Enough said about increased safety. Let's hope your LED technology will never have to be tested in this way.

More economy.

Drivers, fleet managers and business owners alike will very quickly notice the economic advantages of LED technology. LEDs have an extremely long service life. This means: less downtime and repair times, fewer spare parts, fewer delays. In other words, less stress and lower costs. LEDs usually pay off as soon as the first conventional bulb would normally have to be replaced.

More design options.

Despite the minimum amount of space LED components take up on the overall bodywork, their design force is enormous. They can make the vehicle look slimmer, broader, deeper, higher, trendier ... as a trendsetter in the LED sector Hella is opening up a whole new world of design freedom for design engineers.



More design freedom through LEDs.

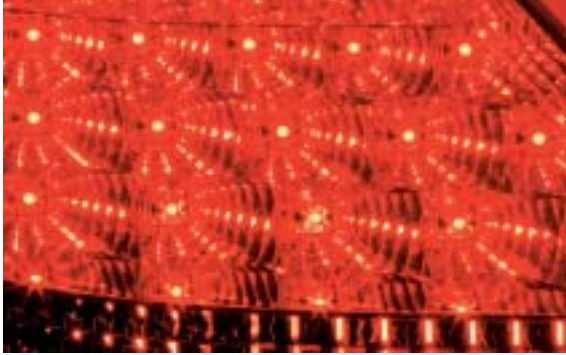

Thanks to the use of LEDs, design engineers have a great deal more design freedom. Ergonomic aspects can also be implemented easily and effectively.

Wide range of technical possibilities through LEDs.

Depending on the requirements on the product or customer wishes, Hella uses LEDs in different optical systems. Here are some examples for combination rearlights:

<p>Direct light</p> <ul style="list-style-type: none"> ■ Spot-shaped appearance ■ No optical system necessary ■ Max. distance between 2 LEDs = 15 mm 		
<p>Fresnel systems</p> <ul style="list-style-type: none"> ■ Suitable for all functions ■ Homogeneous appearance 		
<p>Reflector with pattern/ Lens without pattern</p> <ul style="list-style-type: none"> ■ High degree of effectiveness ■ Brilliant finish 		
<p>Light guide systems</p> <ul style="list-style-type: none"> ■ Elongated appearance ■ Homogeneous illumination ■ Adaptation to curved exterior shape 		



LED indicators and the patented failure check.



Legal requirement in all ECE states

In the case of vehicles approved for use on public roads, the indicators must be monitored: The failure of an indicator must be shown optically or acoustically in the vehicle. This applies in all ECE states. In other words, the potential failure of the indicator must be monitored by the vehicle. Manufacturers use various failure-control systems. The failure check systems currently in use cannot detect simple LED lights and display a fault. All Hella LED indicators have integrated electronics for failure checking. The indicators are self-monitoring. They generate a pulse that is evaluated by the electronic ballast. This ballast simulates a 21 W bulb, which makes operation with conventional flasher units possible.

As soon as one single LED fails, the light can be considered faulty, the pulse is not generated. The ballast then switches the bulb simulation off and the flasher unit indicates the fault to the driver.

Safe conversion to LED indicators now possible thanks to patented Hella electronics

Hella supplies electronic ballasts for all Hella LED indicators which make it possible to convert the indicator failure display for various vehicles. This is necessary if the vehicle manufacturer does not guarantee indicator bulb failure checking via the vehicle electric system. The method has been patented by Hella. At the moment, there are three different ballasts and several different LED indicator types available.



LED light failure check.

The low wattage of LED lights, which distinguishes them significantly from filament bulb versions, can cause problems with the bulb failure check during operation on various traction vehicles.

Since indicator failure checking is required by law, we recommend operating the light only in conjunction with an indicator control unit, Hella part no. 5DS 009 552-... .

In addition, further lighting functions are detected by some traction vehicles. This represents a vehicle comfort function which is not required by law, and does not release drivers from their obligation to see for

themselves that the lighting equipment is working. Here, too, faulty diagnoses may occur due to the lower power levels involved (instrument panel in the driver cab indicates a bulb failure although the function is working).

The functional ability of these bulb failure checks can be established only by the vehicle manufacturer.

LED indicator failure check: Background information.

Why does the failure detection required by law work with various LED lights with some flasher units and not with others?

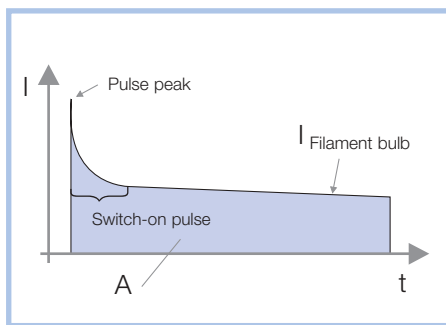

Fig. 1

Fig. 1 illustrates the typical current pattern when a bulb is switched on. Different flasher units detect this in different ways, for example by

- a) measuring the pulse peak or
- b) measuring the current at some point during the switch-on pulse or
- c) measuring the current after the pulse, when the current is constant and has a certain intensity, or
- d) determining the total energy flowing through the light (size of area A)

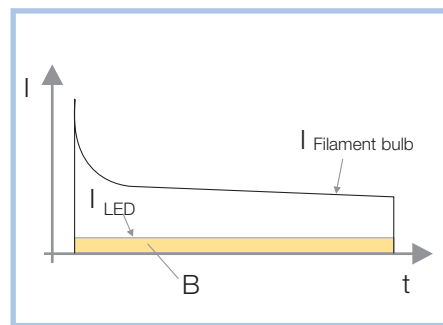

Fig. 2

Fig. 2 shows the LED current (I_{LED}) in relation to this. None of the methods mentioned can work here, because there is neither a switch-on pulse available nor is the current intensity high enough, and another possibility is that the total energy through both lights is identical (area B is as large as A).

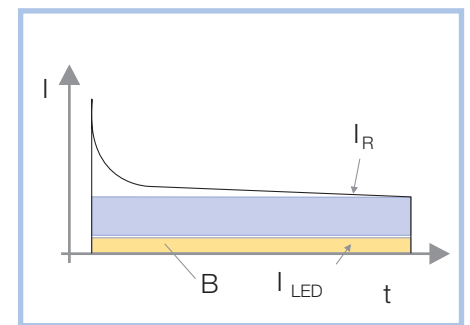

Fig. 3

If a simple Ohmic resistor is inserted, e.g. a resistor cable, the current is increased by a certain value (I_R) and the curve illustrated in **Fig. 3** is the result. In this case, only a flasher unit according to principle c) would work. If the resistance is chosen somewhat higher, principle d) could also possibly work. If the light fails afterwards due to mechanical damage, the flasher unit could detect the inserted resistor as a functional bulb. In this case, a light working perfectly would be indicated although this is not the case! This means: In this case the vehicle would lose its approval for use on public roads.

I = Current
t = Time

LED indicator failure check: The patented Hella solution.

The only solution conceivable for universal use is one that works with all the flasher units on the market. As the above considerations have shown, this can practically only be guaranteed if the current pattern of a bulb is simulated exactly by means of an electronic circuit.

Since such a circuit is extremely complex, it is not possible to integrate this in the LED light. In order to be able to benefit from the advantages of LED lights despite this fact, a ballast is required for the circuit. This combination provides the perfect - and above all legally conforming - solution to the problem.

Hella patent for the perfect problem solution

All Hella LED indicators with integrated electronics for failure control are self-monitoring and generate an individual pulse. This pulse is evaluated by the electronic ballasts. The ballasts simulate a 21 W bulb. This makes operation with conventional flasher units possible. If the light is faulty, which can be the case if only a single LED fails, the above-mentioned pulse is not generated. The ballasts then switch the bulb simulation off and the flasher unit indicates the fault to the driver.

By measuring the light current during a time window of 10 ms (**Fig. 4**), direct exchange between the Hella LED light and a bulb version is possible.

Hella ballasts are straightforward to convert even at a later date.

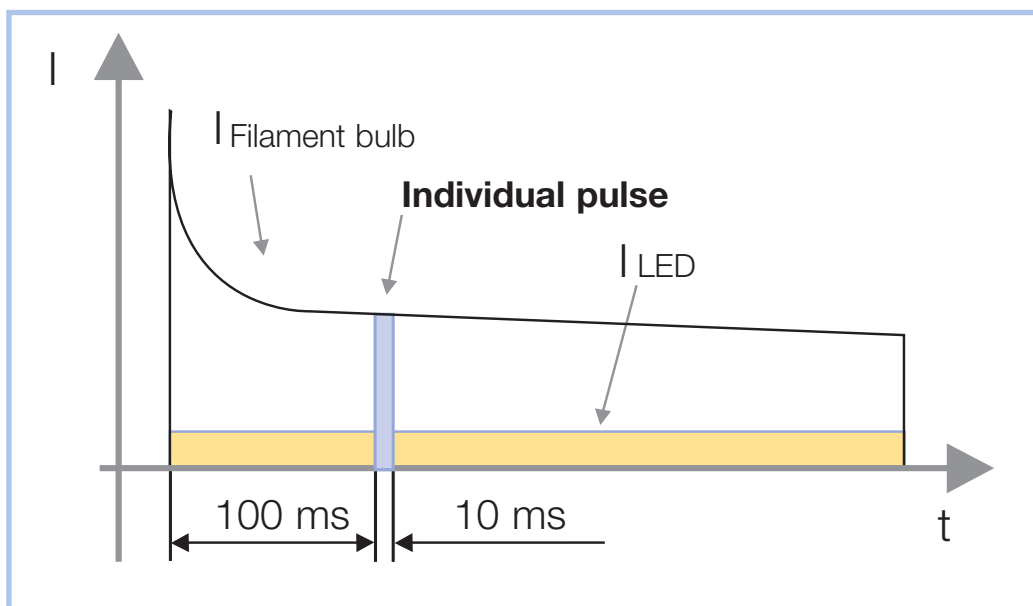

Fig. 4

Vehicle manufacturers can also ensure ECE-conforming failure checking by evaluating the pulse of the Hella LED indicators shown in the adjacent diagram directly in their control units. The exact specification can be obtained from Hella.

Which Hella ballast for which vehicle?

Vehicles that use the cold scan for the indicator failure check.

1.

Description of fault indication:

Is a faulty light indicated when the ignition is switched on or directly when the fault occurs or when the bulb is screwed out without the indicator being triggered?

Solution:

Simulation device for cold scan

Simulation device for cold scan 24 V

Part no. 5DS 009 602-001

12 V on request.



Vehicles without flasher unit that carry out current measurement for the failure check.

2.

Description of fault indication:

Is a fault only determined during flashing (e.g. double flashing frequency)?

Solution:

Indicator control unit

Indicator control units 24 V

- No independent voltage supply is required
- Protective rating IP 6K9K

Part no. 5DS 009 552-001

with EasyConn plug

Part no. 5DS 009 552-011

with blade sliders

Available from 4th quarter 2007.



Vehicles with flasher unit.

3.

Solution: Replacement of the existing flasher unit by an LED flasher unit

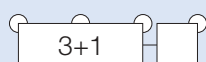
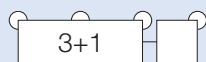
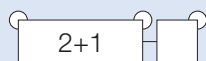

LED flasher unit 12 V 2+1+1

Part no. 4DN 009 492-101

LED flasher unit 24 V 2+1

Part no. 4DM 009 492-001

LED flasher unit 24 V 3+1

Part no. 4DW 009 492-011

LED flasher unit 12 V 3+1

Part no. 4DW 009 492-111





Xenon and Bi-Xenon® light – the high-tech light for the road



Halogen



Xenon

Illumination using xenon light. Xenon light makes the road brighter and illuminates a wider area. Hazards are recognised early.

Xenon light is high on bus and coach drivers' wish lists. Understandable. Because there is nothing they can do about the time of day, weather, width and condition of the road. What they can do something about is the visibility conditions: Xenon light illuminates the roads much brighter and wider than modern H7 filament bulbs, for example. Because it provides more than twice the light - in a colour similar to daylight.

Xenon light accommodates natural human seeing habits. Drivers do not become tired as quickly and are much more relaxed at the wheel. They can detect objects and hazards on the road and at the edge of the roadway much more quickly and easily. Xenon

light improves reaction time and takes the pressure off drivers, both mentally and physically. This makes it not only highly recommendable for long journeys into unfamiliar areas, but also for short trips, scheduled and routine routes.

Xenon light is also profitable thanks to its significantly longer service life in comparison to halogen bulbs. Less downtime and forced breaks for drivers and passengers are good for both company balance and image.

When xenon low beam headlights are used, **headlight cleaning systems and ultrasonic headlight range adjustment** are required by law! (In vehicles with air suspension only the headlight cleaning system is mandatory) (pages 21 + 22).



Anything goes ...

This is an important slogan in design circles. Anything goes in terms of material, shape, colour. Quite often, however, design visions fail to be turned into reality due to trivialities.

On the one hand, the high demands for passenger comfort have to be taken into consideration in bus development, on the other, however, active safety for both driver and passengers. Is there a designer who doesn't dream of a flexible system that would allow him to turn his design ideas for a stylish front-end and an attractive rear-end into reality? In the case of coaches in particular, this aspect has often been neglected in the past. With the Hella lighting concept we offer you this design freedom: a system made up of small but powerful headlights for universal use as well as lighting components for the whole vehicle. A lighting concept where all the lighting elements have been designed to match perfectly.



The advantages of the Hella modular headlight systems:

The use of state-of-the-art lighting technologies such as DE, FF and xenon guarantees forward-looking and powerful lighting performance. Resulting in active safety for both drivers and passengers.

The small light aperture and the clear glass pattern-free cover lens are setting new design trends and opening up a multitude of new possible styling variations for vehicle front-ends for designers.

The use of universal headlights means that expensive development and production costs are a thing of the past. The products required are available quickly and even in small quantities.





... the systems for individual vehicle design:

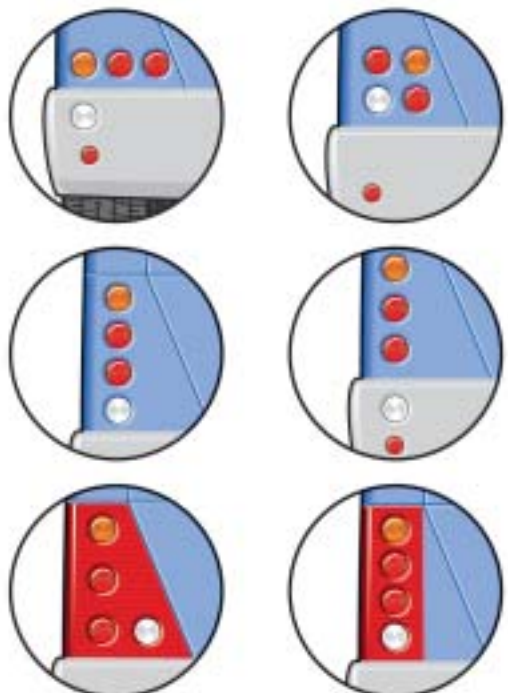
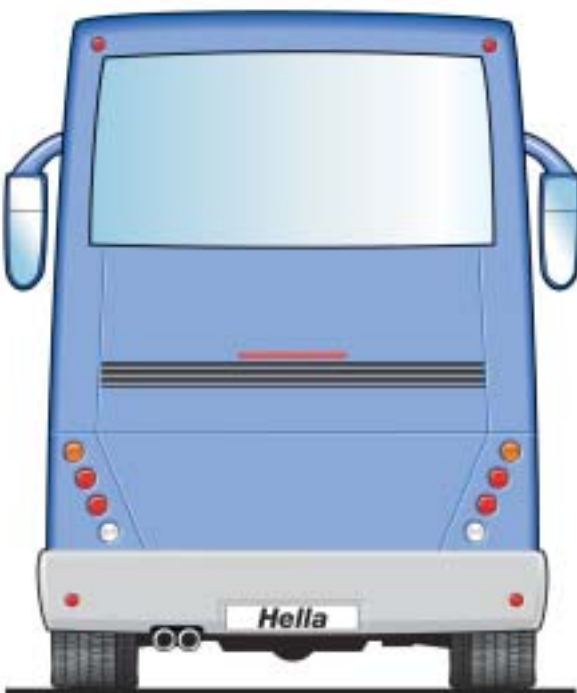
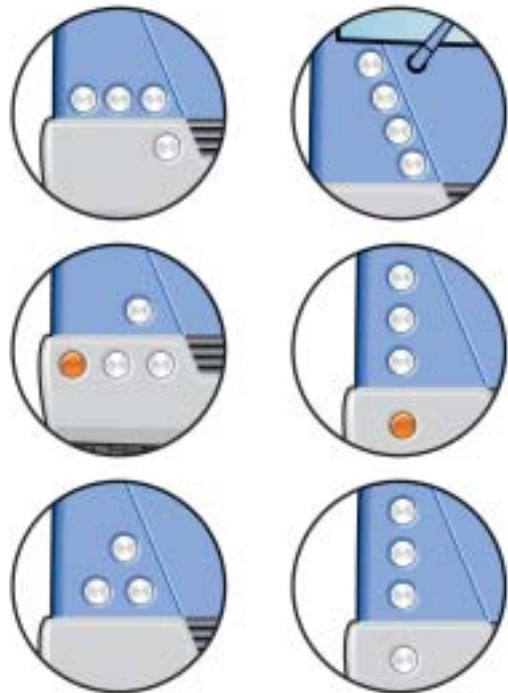
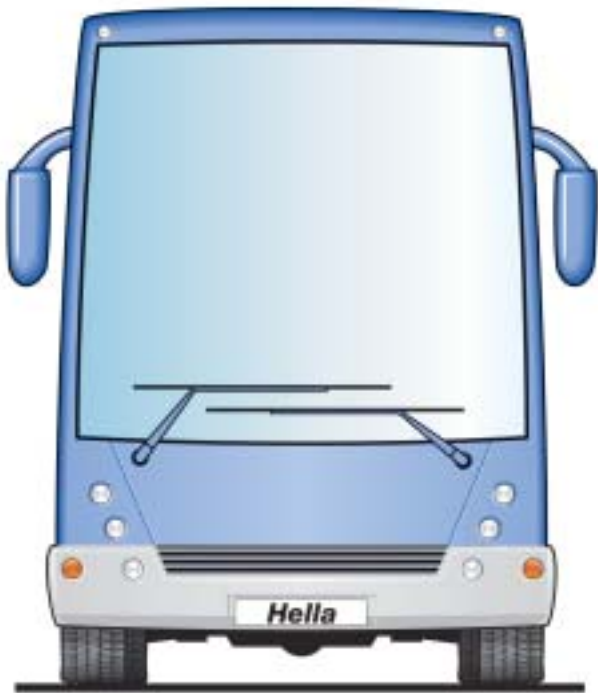

Endless variation possibilities
with the Hella lighting concept.

The modular frontlighting system from Hella.

A successful bus design is a model in two senses of the word. It has its series model number and a face. As well as the shape, it is the headlights that turn the front-end into an unmistakable face. And to avoid new elements having to be dreamed up for every model development, Hella uses the modular frontlighting system. Now, you can turn even a small series into what it needs to be: a unique model from your company. This is how customer-specific headlight development works with Hella:

- You choose the lighting technology: e.g. Xenon or halogen.
- You choose additional options such as daytime running light or DynaView® as required.
- Your designers work with Hella to develop the outer elements such as cover and cover lens.

Imagine: You pick out the elements of a technological modular system and design your brand and model type just the way you want it. All in genuine Hella quality.

Example of a modular series headlight



Auxiliary high beam Fog light Bi-Xenon® (low beam and high beam) Static bend lighting and position light

Components for a modular frontlighting system

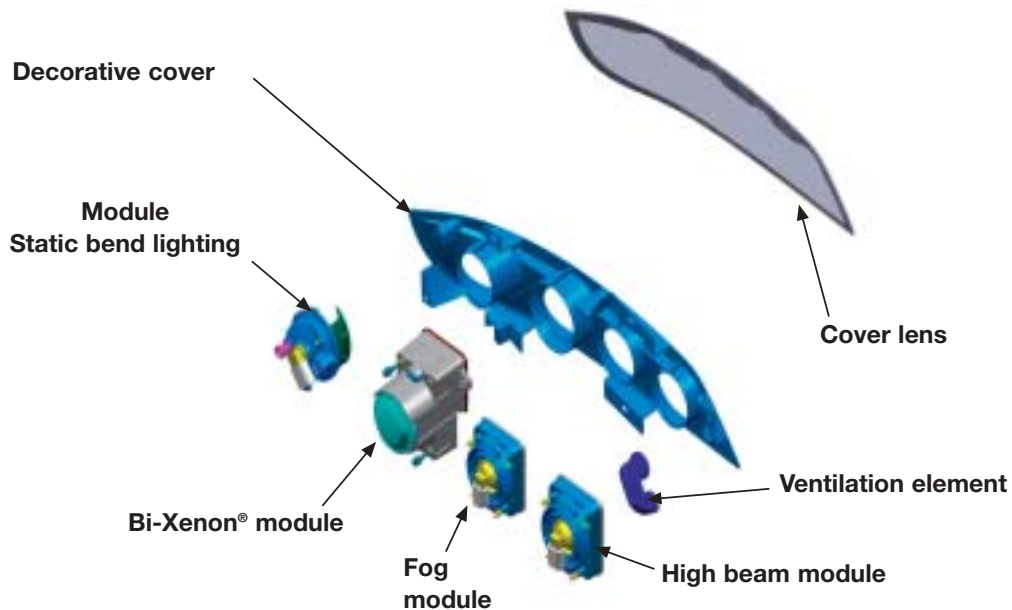

Frontlighting

DynaView® Evo2

A new lighting era.

DynaView® Evo2 combines the safety functions of a cornering light and fog light in compact round auxiliary headlights which can be retrofitted universally to a wide range of vehicles.

With the low beam switched on, the cornering light is activated on the left or right without delay when the indicator is set or automatically when driving round bends at speeds up to 40 km/h (25 mph).

When driving through bends, a yaw rate sensor measures the turning speed of the vehicle and triggers the switching pulse. After the bend, a dimmer gently switches the light cone off again. When the vehicle is put into reverse, both cornering lights switch on and illuminate the areas to the right and left of the vehicle broadly and brightly.



"In a normal driving situation on a straight road, the cornering light is switched off."

"When turning the corner or driving slowly round bends (at speeds of up to 40 km/h (25 mph)) the cornering light is switched on automatically."

"When driving round bends at speeds of up to 40 km/h (25 mph) the respective headlight is switched on fully automatically."

"In foggy conditions, the cornering light (both sides) can be switched on manually in addition as fog light."



DynaView® Evo2 incl. H7 bulb

with hoop bracket, 12 V

Set incl. control electronics	1N0 009 295-801
individual light, left	1N0 009 295-011
individual light, right	1N0 009 295-021

Individual headlight incl. H7 bulb

with carrier frame

12 V, individual left	1N0 009 295-031
12 V, individual right	1N0 009 295-041
24 V, individual left	1N0 009 295-057
24 V, individual right	1N0 009 295-067

IntelliBeam®

Control electronics

5DF 009 244-007

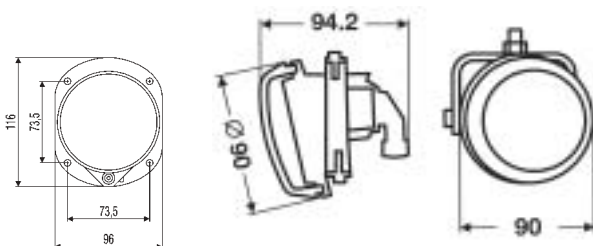

(E1) 1951



Connection plug set

for 20 headlights

8JD 156 151-807

Daytime running light

When do you drive with your lights on during the day?

Studies show: Driving with the lights on during the day brings decisive safety advantages. The vehicle can be seen much more easily and the number of accidents drops dramatically. If less serious accidents are included, it can be said that more than 50 % of all collisions are due to other road users being overlooked.

Further information on the subject of Hella daytime running light can be found on the Internet: www.tagfahrlicht.com

Its superior design makes it a perfect match for modern vehicle front-ends and allows it to be integrated harmoniously into the vehicle design. The new daytime running lights are suitable for universal installation on different vehicles and provide a performance lead:

- The Hella daytime running lights generate a passive, brilliantly white signal light. This gives them a powerful signalling effect and creates a clear safety improvement
- Decisive gain in safety thanks to the special signal image for daytime driving
- Protect drivers from serious accidents
- Automatic switching on and off when the key is turned in the ignition
- Significantly lower fuel consumption than when driving with low-beam light



Low beam – developed for seeing in the dark



Hella LED daytime running light – developed for being seen during the day.



Easily overlooked in the daylight:
no lighting



Optimal only for night-time drives:
conventional low-beam light



Excellent effect:
with special Hella daytime running light

LED

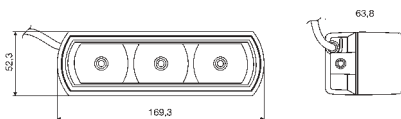

E1 2344

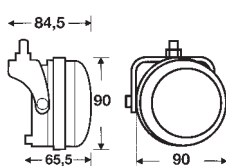

E1 2372

Carrier frame
for flush-
fitting



LED daytime running lights, rectangular design

2 lights incl. harness and universal brackets.
3 high-power LEDs per light, multi-voltage 9 – 33 V
24 V/max. 11 W current consumption
for surface-mounting **2PT 009 496-801**

Individual light without bracket

DRL function only	2PT 009 496-011
DRL with PO function	2PT 009 496-007

LED daytime running lights set, round design

2 lights incl. harness and universal brackets.
3 high-power LEDs per light, multi-voltage 9 – 33 V
24 V/max. 11 W current consumption
for surface-mounting **2PT 009 599-801**

Individual light without bracket

DRL function only, left	2PT 009 599-011
DRL function only, right	2PT 009 599-021
DRL with PO function, left	2PT 009 599-041
DRL with PO function, right	2PT 009 599-031

Universal carrier frame for flush-fitting **9AH 165 968-001**

Frontlighting

Performance

Low beam headlights and spotlights, 90 mm modules

Optimised illumination. Even higher quality modules for use on long journeys.
With splashwater-proof plug-type connection, heavy-duty version.

Halogen



E1 2397

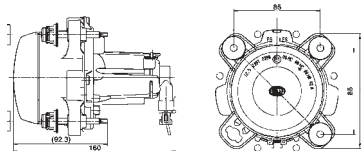

Halogen low beam headlight, 24 V

Module headlight with aluminium reflector and clear DE lens behind pattern-free glass cover lens

Right-hand traffic, H1

1BL 247 042-017

1BL 247 042-011

Left-hand traffic, H1

1ML 247 042-037

Halogen



E1 2397

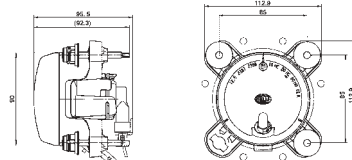

Halogen spotlight, 24 V

Module headlight with aluminium FF reflector and clear DE lens behind pattern-free glass cover lens

with position light, H1

1K0 247 043-027

1K0 247 043-021

Halogen



E1 2397

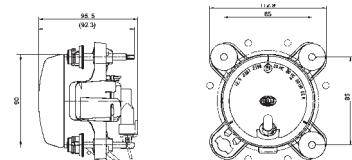

Halogen spotlight, 24 V

without position light, H1

1K0 247 043-037

1K0 247 043-031

Accessories for Performance headlights



Carrier frame
painted black

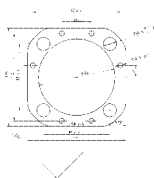

9AH 254 228-017



Connection plug set
Performance + Classic
for 20 headlights

8JD 156 151-807



Actuator motor for headlight range adjustment
for 12 V halogen

6MN 007 282-227



Connection plug set Performance + Classic
for 20 position lights

8JD 156 150-807

Low beam headlights and spotlights, 90 mm modules

Bi-Xenon®



E1 1677

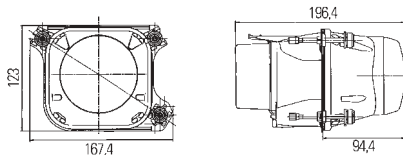

(illustration only shows low beam light distribution)

Bi-Xenon®-headlights

Low beam and high beam from one headlight

Module headlight with integrated ignition unit and pattern-free glass cover lens. High-grade metal reflector. Waterproof xenon ballast, 1 metre shielded supply cable with detachable plug connections

12 V, right-hand traffic	1AL 008 934-001*
12 V, left-hand traffic	1LL 008 934-011*
12 V, right-hand traffic, SAE (USA)	1AL 008 934-041
12 V, right-hand traffic	1AL 008 934-021*
12 V, left-hand traffic	1LL 008 934-031*

Accessories for Bi-Xenon®

Plug for ballast	8JA 990 295-127
Plug for switching to high beam	8JD 162 211-801

Xenon



E1 917

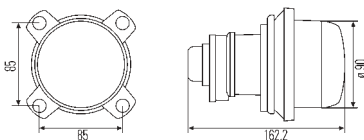

Low beam headlights

Module headlights with pattern-free glass cover lens, magnesium reflectors with clear DE lens

Xenon low beam headlights

12 V, D2S, right-hand traffic	1BL 008 194-007
12 V, D2S, left-hand traffic	1LL 008 194-037
12 V, D2S, USA version	1BL 008 194-047
24 V, D2S, right-hand traffic	1BL 008 194-027
24 V, D2S, left-hand traffic	1LL 008 194-051

Halogen



E1 917

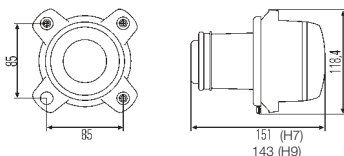

Halogen low beam headlights

12 V, H7, right-hand traffic	1BL 008 193-001
12 V, H7, left-hand traffic	1LL 008 193-117
12 V, H9, USA version	1BL 008 193-021
24 V, H7, right-hand traffic	1BL 008 193-011
24 V, H7, left-hand traffic	1LL 008 193-127

Xenon



E1 917

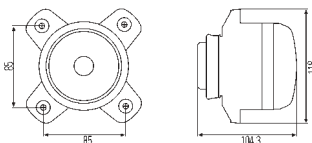

Spotlights

Module headlight with magnesium FF reflectors and pattern-free glass cover lens.

Xenon spotlights

12 V, with position light	1K0 008 192-007
12 V, ohne Positionslicht	1K0 008 192-017
24 V, with position light	1K0 008 192-027

Halogen



E1 917

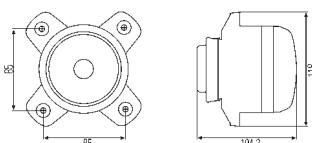

Halogen spotlights

12 V, with position light	1K0 008 191-001
12 V, without position light	1K0 008 191-017
12 V, without position light, USA version	1K0 008 191-051
12 V, with position light, USA version	1K0 008 191-131
24 V, with position light	1K0 008 191-021
24 V, without position light	1K0 008 191-041

Xenon low beam only permissible with headlight range adjustment and lens cleaning system. See page 21 + 22.

Frontlighting

Accessories for Classic, Performance and fog lights, 90 mm module

Accessories for Classic



Rubber caps for 90 mm halogen H7, Classic

Low beam headlights 008 193-...
non-ventilated

flat version for angled plugs

9GH 152 654-012

deep version for socket housing

9GH 145 943-012



Spotlights 008 191-...
ventilated

flat version for angled plugs

9GH 152 654-007

deep version for socket housing

9GH 145 943-001

Halogen H9:

Sealed through connection system, no cap required



Connection plug set Classic

H9 008 191-... and 008 193-..., for USA version
for 20 headlights

8JD 158 175-807



Connection plug set

Classic + Performance

for 3rd generation xenon ballasts, halogen and
DynaView® Evo2
for 20 headlights

8JD 156 151-807



Connection plug set Classic + Performance

for 20 position lights

8JD 156 150-807

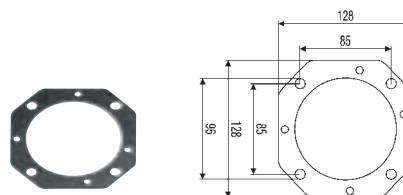

Carrier frame Classic

for low beam headlights and spotlights

9AH 157 659-007



Actuator motors for headlight range adjustment Classic
for 24 V halogen headlights

6NM 008 299-501

E1 1342

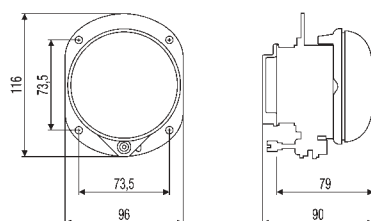

Fog lights 90 mm

Minimum installation dimensions for a discreet but convincing
light design. Aluminium reflectors with clear lens.
Ideal in combination with the matching 90 mm spotlights and
low beam headlights.

Halogen fog light

12 V **1N0 008 582-007**
24 V **1N0 008 582-017**

Accessories: Rubber cap

for fog lights

9GH 158 051-007

Frontlighting

50 mm Premium headlight modules

Xenon

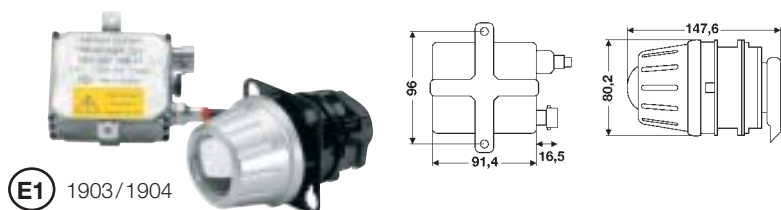

E1 1903/1904

Low beam headlights

Installation frame for 3-point fastening, adjustable from the front and rear

Xenon

12 V, D2S, right-hand traffic	1BL 009 071-047
12 V, D2S, left-hand traffic	1ML 009 071-057
24 V, D2S, right-hand traffic	1BL 009 071-067
24 V, D2S, left-hand traffic	1ML 009 071-077

Halogen



E1 1903/1904

Halogen

12 V, H7, right-hand traffic	1BL 009 071-007
12 V, H7, left-hand traffic	1ML 009 071-017
24 V, H7, right-hand traffic	1BL 009 071-027
24 V, H7, left-hand traffic	1ML 009 071-037

Xenon

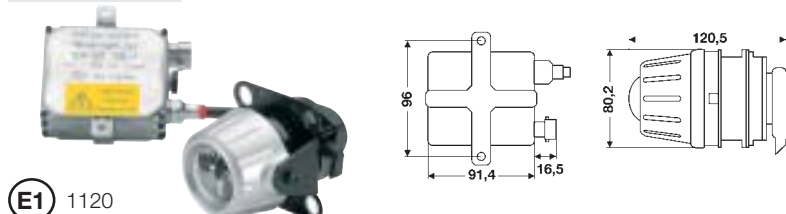

E1 1120

Spotlights

3-point attachment, setting screw adjustment

Xenon

rear carrier frame is not part of the scope of supply (see accessories)

12 V, D2S	1F0 008 390-317
24 V, D2S	1F0 008 390-327

Halogen



E1 2198

Halogen

12 V, H9	1KL 009 486-001
----------	------------------------

(connection plug see page 18)



E1 877

Fog light

3-point attachment, setting screw adjustment, rear carrier frame is not part of the scope of supply (see accessories)

12 V, H7	1NL 008 090-317
24 V, H7	1NL 008 090-327

Accessories for 50 mm headlight modules



Carrier frame (not for halogen spotlights)

- ① without headlight range adjustment fixture **9AH 161 786-017**
- ② with headlight range adjustment fixture **9AH 161 784-017**



Plastic cap

for fog lights **9HD 149 253-007**

Rubber cap

- ① for halogen low beam headlights **9GH 152 654-007**
- ② for fog lights **9GH 147 009-007**



Actuator motors for headlight range adjustment

for 24 V halogen **6NM 008 299-501**



Connection plug set, fog light

for plastic cap **8JD 156 150-807**

Frontlighting

Lens cleaning systems

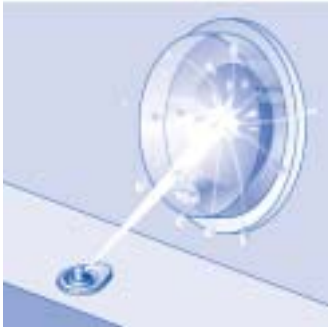

E1 0130

with stationary nozzles

12 V **8WS 008 549-001**

24 V **8WS 008 549-501**

as **8WS 008 549-001**,
but with longer cables

12 V **8WS 008 549-011**

24 V **8WT 008 549-601**



with single telescopic nozzles

12 V **8WT 008 549-101**

24 V **8WT 008 549-601**



with double telescopic nozzles

12 V **8WT 008 549-201**

24 V **8WT 008 549-701**

Legislation requires the use of a lens cleaning system whenever xenon low beam headlights are used. (The use of such a system is also recommended for halogen headlights and spotlights.)

Hella cleaning systems use the water jet principle which manages without wipers and brushes by using the kinetic energy of large water drops which are blasted off the lens and then rinsed away together with the dirt particles.

The water pressure required for the cleaning process is produced by a redary pump which is then used to form high-speed water drops inside special Hella vortex-chamber nozzles. Specially designed valves in front of the nozzles prevent water escaping from the higher placed storage tank and also help to save water.

Hella also has a solution for such cases where these stationary nozzles cannot be used due to unfavourable lens systems: telescopic nozzle systems which move into the required working position as long as they are needed for the cleaning process.

These lens cleaning systems have ECE type approval for the following Hella headlight model series when installed according to the manufacturer's instructions.

Ø 50 mm: **1BL 009 071-...**
1ML 009 071-...
1F0 008 390-...

Ø 90 mm: **1KO 008 191-...** **1AL 008 934-...**
1KO 008 192-... **1LL 008 934-...**
1BL 008 193-... **1BL 247 042-...**
1BL 008 194-... **1BL 247 043-...**

Frontlighting

Ultrasonic headlight range adjustment (H/L)

The ultrasonic system is a versatile H/L system which can be used as original equipment and for retrofitting to vehicles with xenon low beam headlights of the Hella model series 008 194-..., 009 071-..., 008 934-..., 009 997 Type-approved in combination with the above-mentioned headlight model series.

The system sensor measures the distance from the underside of the vehicle to the road surface, forwards the signal to the central control unit which then achieves optimum setting of the xenon headlights via the setting motors.

See installation instructions for detailed information.

Optimum sensor placement

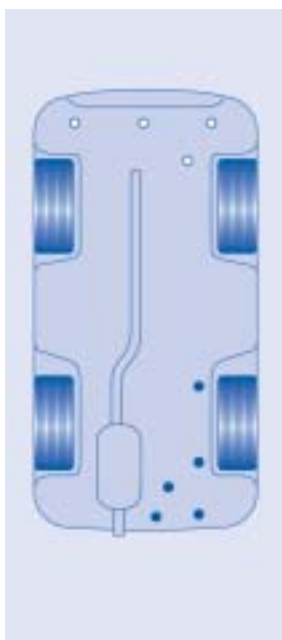

Sensor installation



Installation fittings



E1 917

12 V, one sensor (passenger cars)

8XX 008 614-011

12 V, two sensors (3.5 t)

8XX 008 614-031

24 V, two sensors (CV)

8XX 008 614-101

Add-on set / 2nd sensor

8XX 008 644-001

incl. wiring assembly

System structure in the vehicle

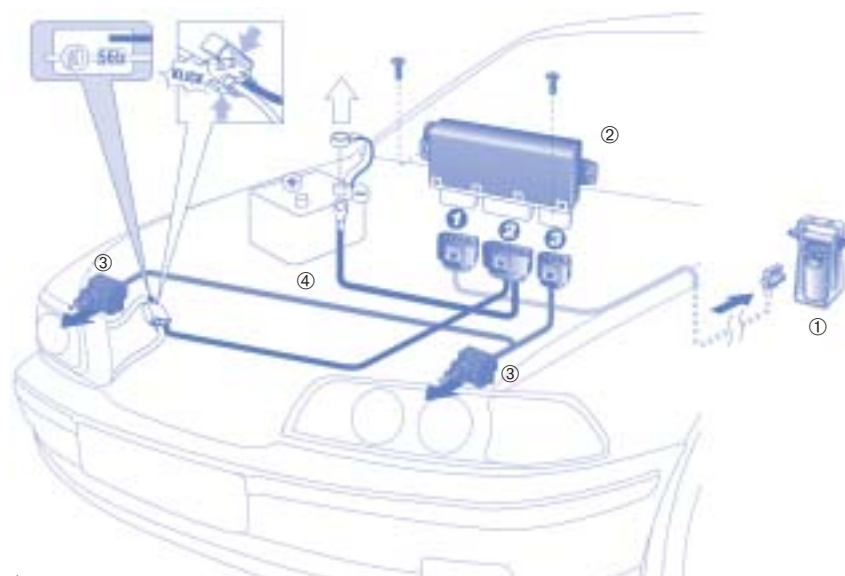

- ① Ultrasonic sensor
- ② Control electronics
- ③ 2 headlight range adjustment actuators
- ④ Wiring harness

(Setting motors etc. see pages 16, 18 and 19)

Frontlighting



E1 877/1120

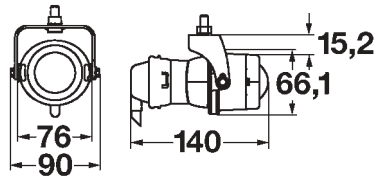

Micro DE Premium Edition Halogen auxiliary light set Fog light

with radio frequency switching system
and aluminium design ring

E1

1NL 008 090-301

Spotlight

1F0 008 390-301



E1 877

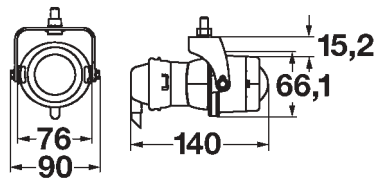

Micro DE Halogen auxiliary light set Fog light

with black decorative ring

1NL 008 090-821

with universal radio frequency switching system

1NL 008 090-831



E1 15

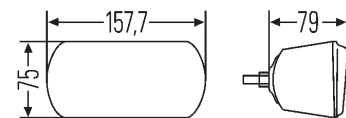

Comet 300 Fog light

with crown fixture, for flush-fitting,
H3 fog light, without bulb

left 1NB 007 360-011

right 1NB 007 360-021



E1 20

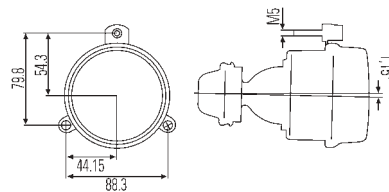

Fog light

for flush-fitting, light aperture \varnothing 80 cm

with 12 V bulb 1NL 007 186-027

with 24 V bulb, plastic cap,

cover and wiring 1NL 007 186-047

Available rear protective caps

Plastic cap 9GH 147 009-007

Plastic cap with cover

and wiring 9GH 149 253-007



E1 878/879

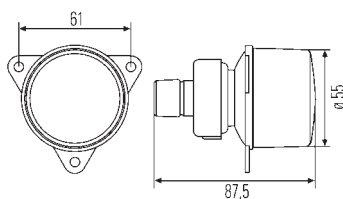

Indicator

E1 878

for 12 and 24 V

2BA 008 221-001

with amber 12 V/21 W bulb fitted

2BA 008 221-107

Position light

E1 879

(not illustrated, version as indicator)

2PF 008 221-011

Harness with grommet

8KA 152 134-007

LED

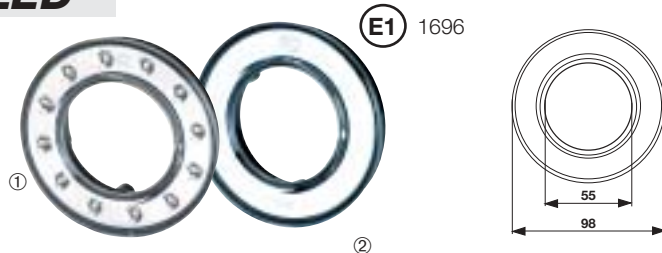

① LED circular position light

for flush-fitting

12 V **2PF 008 405-061¹**

24 V **2PF 008 405-051¹**

Can be combined with 55 mm Premium lights.

12 V / 1.8 W current consumption = approx. 0.15 A

24 V / 1.8 W current consumption = approx. 0.08 A

② Chrome-plated circular plate

for flush-fitting

8XU 008 405-301



E4 6546/7613

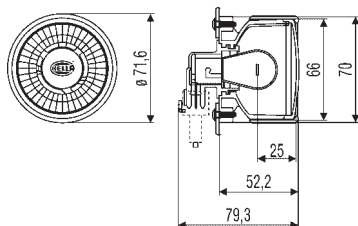

60 mm Premium lights

E4

Type approval

		ECE	SAE (USA)
Indicator			
12 V	2BA 009 001-071	X	
12 V	2BA 009 001-091		■
24 V	2BA 009 001-167	X	
with Silver Vision bulb (only 12 V)			
12 V	2BA 009 001-201	X	
Position light			
12 V	2PF 009 001-081	X	■
24 V	2PF 009 001-177	X	



E4 10215

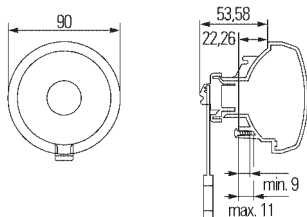

max. installation depth

90 mm

Type approval

		ECE	SAE (USA)
Indicator			
12 V	2BA 965 039-067	X	■
24 V	2BA 965 039-147	X	■
Position light			
12 V	2PF 965 039-077	X	■ ●
24 V	2PF 965 039-157	X	■
Daytime running light, 21 W			
12 V	2PT 965 039-161		
24 V	2PT 965 039-171		



E4 10202

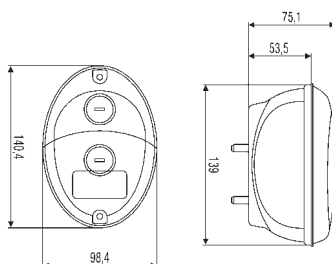

Oval light series

for horizontal and vertical surface-mounting

Indicator, without bulb,

12/24 V **2BA 343 130-057** X ■ ●

Indicator/position light, without bulb,
12/24 V **2BE 343 130-007** X ■

(depending on the installation position, the water draining opening must be broken open, see installation instructions)

LED

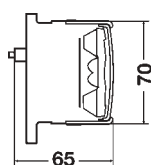

60 mm Premium LED light

Position light, for flush-mounting, with 12 LEDs

12 V **2PF 009 001-421¹** X

24 V **2PF 009 001-521¹** X

12 V/1.5 W current consumption

■ SAE type approval for vehicles < 2,032 mm in width
● SAE type approval for vehicles ≥ 2,032 mm in width

¹ See the note on page 6 regarding LED light failure check.

LED



(E4) 7575

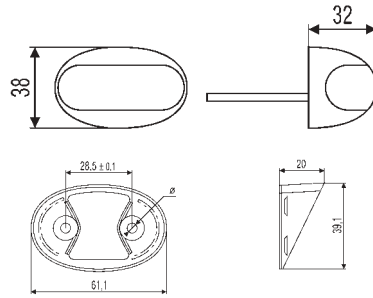

Position light

for horizontal surface-mounting,
White housing

with 500 mm cable, 10 V – 33 V **2PF 959 570-427¹**

with matching white 25° adapter base
(order separately) **8HG 959 571-007**

12 V / 0.5 W current consumption = approx. 0.04 A

24 V / 0.5 W current consumption = approx. 0.02 A

LED



(E4) 7575

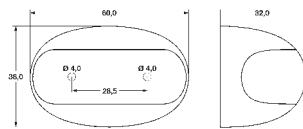

Position light

for horizontal surface-mounting

with 500 mm cable, 10 V – 33 V **2PF 959 570-401¹**

with 5,000 mm cable, 10 V – 33 V **2PF 959 570-411¹**

12 V / 0.5 W current consumption = approx. 0.04 A

24 V / 0.5 W current consumption = approx. 0.02 A

LED

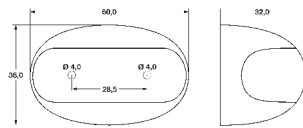

Amber position light

in LED technology, 12 V,

with 500 mm cable

for horizontal surface-mounting

2PS 959 660-207¹

12 V / 0.5 W current consumption = approx. 0.04 A

Type approval

ECE

SAE



LED



(E1) 2300

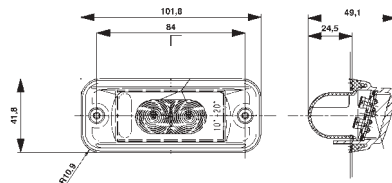

Position light for flush-mounting,

with 2 white LEDs.

for mounting position 10 – 20° **2PF 009 514-001¹**

for mounting position 20 – 30° **2PF 009 514-011¹**

24 V / 0.5 W current consumption = approx. 0.02 A

LED



(E4) 7597

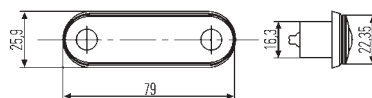

Position light

for horizontal and vertical flush-fitting

with 500 mm cable, 10 V – 33 V **2PF 959 590-401¹**

with 5,000 mm cable, 10 V – 33 V **2PF 959 590-411¹**

12 V / 0.5 W current consumption = approx. 0.04 A

24 V / 0.5 W current consumption = approx. 0.02 A



(E1) 31446

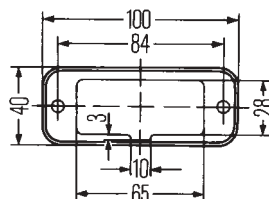

Position light

without reflector

2PF 961 167-021

LED

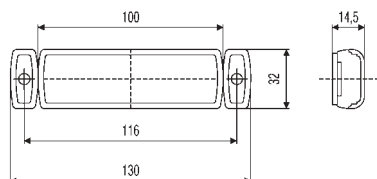

Position light

with reflector,
for vertical and horizontal surface-mounting

with 500 mm cable, 24 V **2PG 008 645-041¹**

with 5,000 mm cable, 24 V **2PG 008 645-051¹**

Rubber seal (please order separately)

55 pieces **9GD 157 876-007**

24 V / 0.9 W current consumption = approx. 0.04 A

LED



E17 002

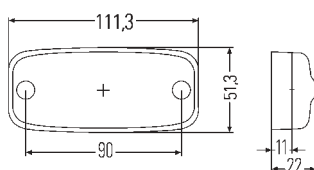

Position light

with 2 LEDs, with reflector, 24 V

with 500 mm cable **2PG 963 639-401¹**

with 5,000 mm cable **2PG 963 639-411¹**



E4 7499

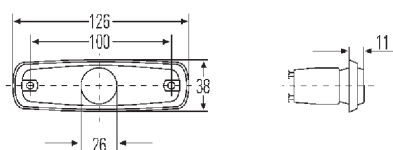

Position light

for vertical flush-fitting,
with pre-fitted 24 V / 5 W bulb

without reflector (not illustrated) **2PF 962 964-061**

Seal (please order separately) **9GD 963 281-001**

Grommet (please order separately) **9GT 963 129-001**

LED



E17 811/9806

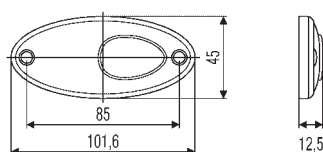

Position light

for horizontal surface-mounting,
with reflector, with 2 LEDs **E17**

12 V 9806 **2PG 964 295-121¹**

24 V 9806 **2PG 964 295-111¹**

as above, but with
adapter base 30°,
without reflector **E17**

12 V 811 **2PF 964 295-257¹**

12 V / 0.3 W current consumption = approx. 0.03 A

24 V / 0.6 W current consumption = approx. 0.03 A



E1 584

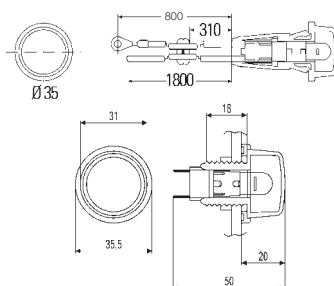

Position light

for 12 V and 24 V, with 800 mm ground cable
and 1,800 mm positive lead **2PF 003 563-151**

as -151, but without positive lead **2PF 003 563-167**

Light mounted with M 20 x 1.5 plastic nut;
without cable, with flat plug connection

with 12 V bulb **2PF 003 563-177**

with 24 V bulb **2PF 003 563-187**

■ SAE type approval for vehicles < 2,032 mm in width
● SAE type approval for vehicles ≥ 2,032 mm in width

¹ See the note on page 6 regarding LED light failure check.

Clearance lighting

LED

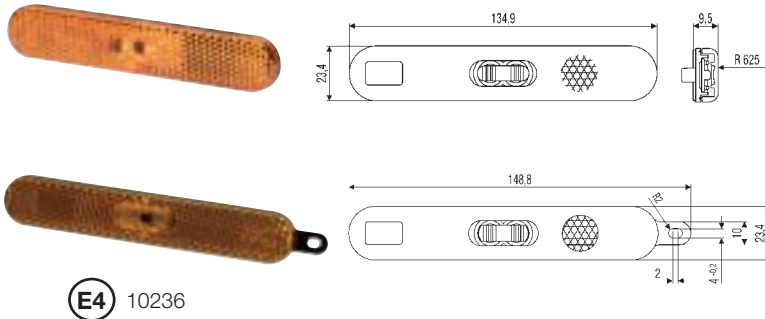

E4 10236

Side marker light

with reflector in LED technology, with 2 LEDs
with cable 195 mm long, self-adhesive,
with AMP plug housing

24 V **2PS 009 226-017¹**

24 V/1.0 W current consumption = approx. 0.06 A

without AMP plug housing

12 V **2PS 009 226-027¹**

24 V **2PS 009 226-037¹**

12 V/0.5 W current consumption = approx. 0.06 A

24 V/1.0 W current consumption = approx. 0.06 A

LED

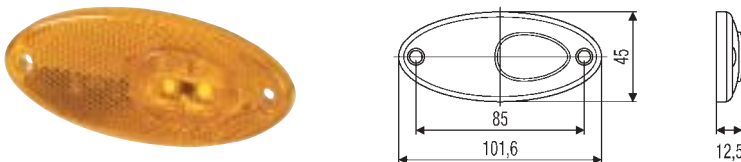

E17 0202

Side marker light

with reflector, with 2 amber LEDs, with seal and
two cables 500 mm long, for horizontal surface-mounting

with fastening screws

12 V **2PS 964 295-067¹**

24 V **2PS 964 295-057¹**

self-adhesive (for smooth and clean surfaces)

12 V **2PS 964 295-087¹**

24 V **2PS 964 295-077¹**

12 V/0.5 W current consumption = approx. 0.04 A

24 V/1.0 W current consumption = approx. 0.04 A

LED

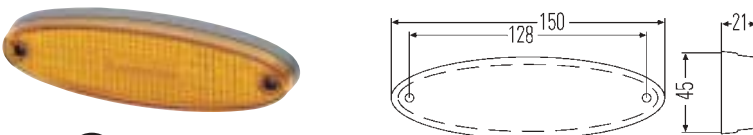

E4 9417

Side marker light

with reflector, for horizontal surface-mounting, with 3 LEDs,
grey base plate. With 500 mm cable and stripped
ends. 2 holes, Ø 4.5 mm, for fastening screws.

12 V **2PS 007 943-317¹**

24 V **2PS 007 943-017¹**

12 V/0.7 W current consumption = approx. 0.06 A

24 V/1.0 W current consumption = approx. 0.04 A

LED

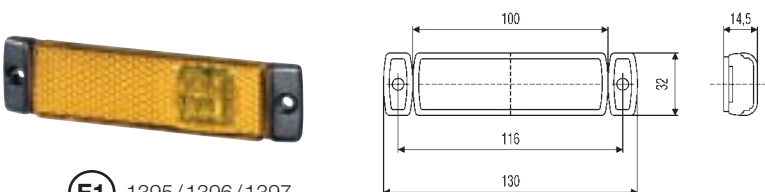

E1 1395/1396/1397

Side marker light

with LED technology, with two-wire hose line 1,500 mm long,
for horizontal surface-mounting

12 V **2PS 008 645-011¹**

24 V **2PS 008 645-001¹**

for vertical surface-mounting

12 V **2PS 008 645-031¹**

24 V **2PS 008 645-021¹**

Rubber seal (please order separately)

55 pieces **9GD 157 876-007**

12 V/0.6 W current consumption = approx. 0.05 A

24 V/1.2 W current consumption = approx. 0.05 A

Clearance lighting

LED

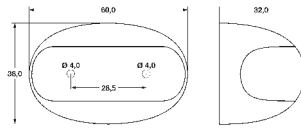

Side marker light

(according to SAE the last side marker light must be red) in LED technology, 12 V, with 500 mm cable

for horizontal surface-mounting

Type approval

	ECE	SAE
amber	2PS 959 660-207 ¹	■ ●
red	2PS 959 660-407 ¹	■ ●

12 V / 0.5 W current consumption = approx. 0.04 A

LED

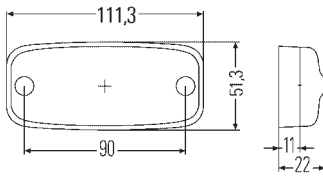
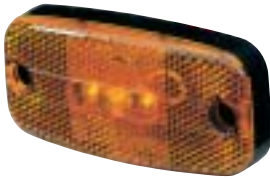

Side marker light

for horizontal surface-mounting, with reflector,

3 built-in LEDs, with base and 2 holes

Ø 4.5 mm for fastening screws

with 1,500 mm cable **2PS 963 639-177¹**

with 5,000 mm cable **2PS 963 639-137¹**

24 V/1.3 W current consumption = approx. 0.05 A

E17 9605

LED

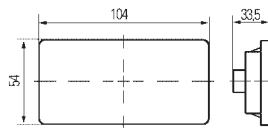
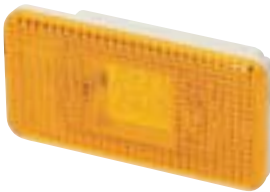

Side marker light

for horizontal and vertical flush-fitting, with reflector, with extremely shallow design depth, with 500 mm cable

2PS 007 972-011¹

24 V/1.0 W current consumption = approx. 0.04 A

E1 508

Auxiliary indicator, Category 6

for 12 and 24 V/21 W

left **2BM 006 692-011**

right **2BM 006 692-021**

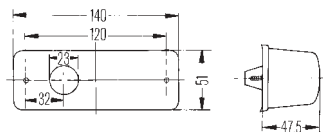

E1 52621

Auxiliary indicator, Category 6

for 12 V and 24 V/21 W, extremely slim design

amber **2BM 008 355-001**

white **2BM 008 355-017**

Harness for non-

splashwater-protected area **8KA 157 425-007**



E1 1848

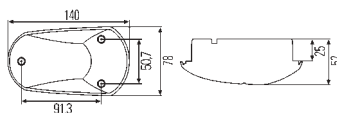

E1 1059

For commercial vehicles < 6 m in length and/or < 3.5 t in weight, Category 5 auxiliary indicators are mandatory, and for vehicles > 6 m in length and/or > 3.5 t in weight, Category 6 auxiliary indicators are mandatory.

■ SAE type approval for vehicles < 2,032 mm in width
● SAE type approval for vehicles ≥ 2,032 mm in width

¹ See the note on page 6 regarding LED light failure check.

Rear lighting

The modular rear light system from Hella.

As with headlights, a customer-specific combination rear light gives the bus a characteristic appearance. To achieve these – especially for small series – Hella relies on the modular concept tried and trusted in the headlight sector for rear lighting too. Engineers, designers and financial controllers are all equally delighted with this. The modular system provides the whole range of design possibilities – from futuristic through dynamic, sporty, matter-of-fact, elegant or classic. Here you will find solutions that no-one else has. By using existing modules, costs can be kept low even for small series. You choose the technology – bulbs or innovative LED lighting. Your designers set the specific model style with bespoke light module seats and cover lenses.

Components for modular rear light system

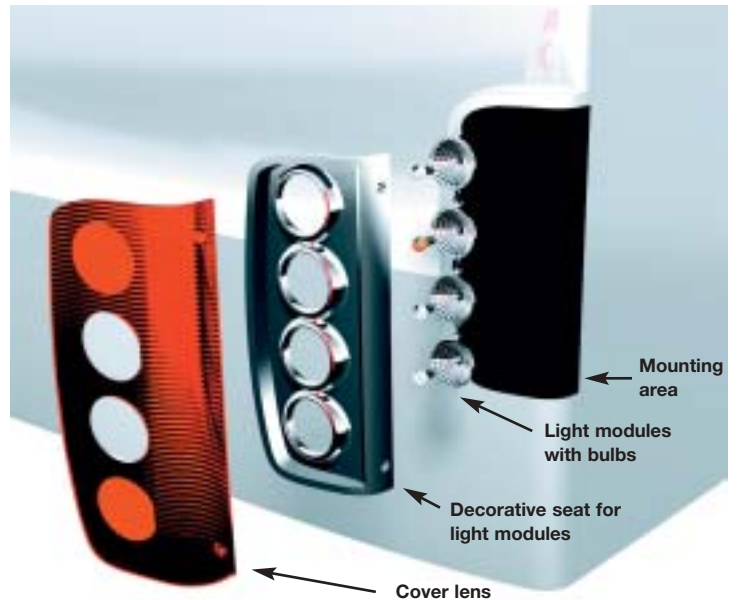

Series light made up of the modular concept



LED

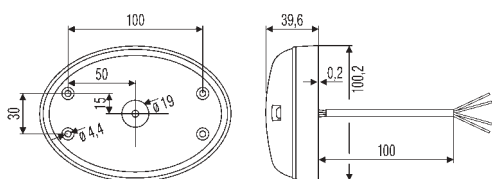

"Oval" combination rear light

for horizontal and vertical surface-mounting, clear-glass lens,
24 LEDs, can be used right and left, turned through 180°,
2 body fastening screws (diagonal arrangement)
with cable 100 mm long, multi-volt 9 – 32 V

All LED lights have been designed for operation in DC voltage networks.
Their operation with pulsed supply voltage or alternating current is not
permissible.

	E4	Type approval	
		ECE	SAE (USA)
2SD 343 390-017¹	① ② ③	X	
2SD 343 390-027¹	① ② ③		●
12 red LEDs for stop light			
12 V/1 W current consumption = approx. 0.08 A			
24 V/1.2 W current consumption = approx. 0.05 A			
12 red LEDs for taillight reduced power			
12 V/0.2 W current consumption = approx. 0.02 A			
24 V/0.5 W current consumption = approx. 0.02 A			
12 amber LEDs for indicator (SAE version 12 red LEDs)			
with patented electronics for indicator failure check			
12 V/1.5 W current consumption = approx. 0.13 A			
24 V/1.6 W current consumption = approx. 0.07 A			
2SA 343 390-037¹	①	X	
2SA 343 390-047¹	①		●
12 V/0.2 W current consumption = approx. 0.02 A			
24 V/0.5 W current consumption = approx. 0.02 A			
2DA 343 390-057¹	②	X	
2DA 343 390-067¹	②		●
12 V/1 W current consumption = approx. 0.08 A			
24 V/1.2 W current consumption = approx. 0.05 A			
2BA 343 390-077¹	③	X	
2BA 343 390-087¹	③		●
12 V/1.5 W current consumption = approx. 0.13 A			
24 V/1.6 W current consumption = approx. 0.07 A			
24 amber LEDs; (SAE version 24 red LEDs)			
with patented electronics for indicator failure check			
2SB 343 390-097¹	① ②	X	
2SB 343 390-107¹	① ②		●
Stop light:	12 V/1 W current consumption = approx. 0.08 A		
	24 V/1.2 W current consumption = approx. 0.05 A		
Taillight:	12 V/0.2 W current consumption = approx. 0.02 A		
	(reduced power)		
	24 V/0.5 W current consumption = approx. 0.02 A		

■ SAE type approval for vehicles < 2,032 mm in width
● SAE type approval for vehicles ≥ 2,032 mm in width

¹ See the note on page 6 regarding LED light failure check.

① Taillight ② Stop light ③ Indicator ④ Rear fog light ⑤ Reverse light
⑥ Reflector ⑦ Side marker light with reflector ⑧ Licence plate light ⑨ Parking light

Rear lighting

LED



E4 12371

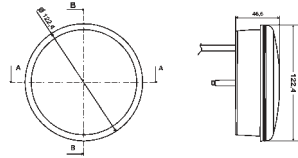

Combination rearlight

for flush-fitting, clear-glass lens,
Multi-volt 9 – 32 V

Type approval
ECE | SAE
(USA)

	① ② ③	X	■
2SD 344 200-017¹			
Taillight:	12 V/1 W current consumption = approx. 0.08 A 24 V/1 W current consumption = approx. 0.04 A		
Stop light:	12 V/1.5 W current consumption = approx. 0.13 A 24 V/1.5 W current consumption = approx. 0.06 A		
Indicator:	12 V/2 W current consumption = approx. 0.17 A 24 V/2 W current consumption = approx. 0.08 A with pulse for indicator failure check		

LED



E4 12373

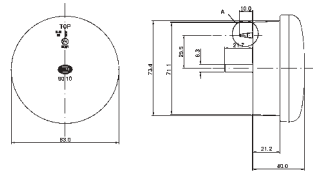

Combination rearlight

for flush-fitting

Type approval
ECE | SAE

	① ②	X	
2SB 959 010-301¹			
2BA 959 011-301¹	③		
Taillight:	24 V/3 W current consumption = approx. 0.13 A		
Stop light:	24 V/1 W current consumption = approx. 0.04 A		
Indicator:	24 V/3 W current consumption = approx. 0.13 A with pulse for indicator failure check		

LED



E4 10208

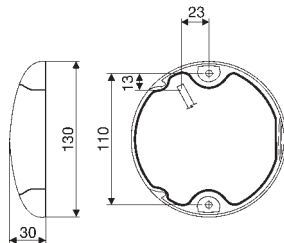

EuroLED

for surface-mounting, cast in one piece with black base plate,
electrical connection through a cable 2,500 mm long,
Multi-volt 9 – 33 V, with 1 Power-LED

Type approval
ECE | SAE
(USA)

	① ②	X	
2SB 959 821-601¹			
2ZR 959 820-601^{1,2}	⑤		
2BA 959 822-601¹	③		
12 V/2.5 W current consumption = approx. 0.21 A 24 V/2.5 W current consumption = approx. 0.10 A			
2NE 959 821-201¹	④		
12 V/4 W current consumption = approx. 0.33 A 24 V/4 W current consumption = approx. 0.17 A with pulse for indicator failure check			
SAE versions on request.			

4DM 009 492-001 LED flasher unit with failure check 2 plus 1

4DM 009 492-011 LED flasher unit with failure check 3 plus 1

Rear lighting

LED

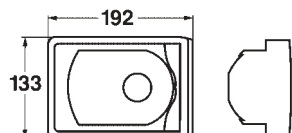

(E4) 10880

4DM 009 492-001 LED flasher unit with failure check 2 plus 1

4DM 009 492-011 LED flasher unit with failure check 3 plus 1

Combination rearlight

with 32 LEDs, brilliant finish,
for horizontal flush-fitting

2SB 008 982-007¹ ① ② red lens
24 V/3 W consumption = approx. 0,13 A

2SB 008 982-307¹ ① ② red lens
12 V/3 W consumption = approx. 0,25 A

2BA 008 982-047¹ ③ clear-glass lens
24 V/2 W current consumption = approx. 0.08 A

Lights with pulse generator

Type approval

ECE SAE
(USA)

X ■ ●

X ■ ●

X ■ ●

X ■ ●

X ■ ●

X ■ ●

X ■ ●

Accessories

8GD 159 740-007 Seal

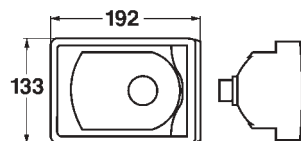

(E4) 10151

Combination rearlight

brilliant finish,
for horizontal and vertical flush-fitting

2SA 008 805-007 ①

2DA 008 805-017 ②

2SB 008 805-027 ① ②

2BA 008 805-057 ③ clear-glass lens

2BA 008 805-187 ③ amber lens

2NE 008 805-077* ④

2NE 008 805-037* ④

2ZR 008 805-047² ⑤

* horizontal flush-fitting only

8GD 159 740-007 Seal

Type approval

ECE SAE
(USA)

X ■ ●

X ■ ●

X ■ ●

X ■ ●

X ■ ●

X ■ ●

X ■ ●

X ■ ●

X ■ ●

X ■ ●

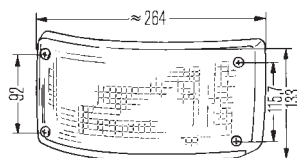

(E1)

Combination rearlight

for horizontal flush-fitting

(E1)

2SA 005 603-021 ① 31423

2DA 005 603-031 ② 31422

2SB 005 603-137 ① 2340

2BA 005 603-047 ③ 42749

2BA 005 603-011 ③ amber lens 42749

2BA 005 603-117 ③ red lens 586

2NE 005 603-071 ④ 8438

2ZR 005 603-061² ⑤ 8770

Type approval

ECE SAE
(USA)

X ■ ●

X ■ ●

X ■ ●

X ■ ●

X ■ ●

X ■ ●

X ■ ●

X ■ ●

■ SAE type approval for vehicles < 2,032 mm in width

● SAE type approval for vehicles > 2,032 mm in width

① Taillight

② Stop light

③ Indicator

④ Rear fog light

⑤ Reverse light

⑥ Reflector

⑦ Side marker light with reflector

⑧ Licence plate light

⑨ Parking light

¹ See the note on page 6 regarding LED light failure check.

² New vehicle types registered for the first time from July 2008 onwards and larger than 6,000 mm in length (except for M1 models) have to be fitted with 2 reversing spotlights. M1 models = Vehicles up to 3.5 tons and 9-person transport capacity

Rear lighting

LED



E13 0533

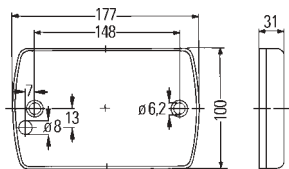

E13 0363

DuraLED

for horizontal or vertical surface-mounting, clear-glass lens, with 36 LEDs and potted cable 2,400 mm long with stripped cable ends, Multi-volt 9 – 33 V

Type approval	
ECE	SAE (USA)

2SP 959 060-601¹ ① ② ③

12 V/13 W, current consumption = approx. 1.08 A
24 V/13 W, current consumption = approx. 0.54 A

X	
----------	--

2BA 959 070-631¹ ③

12 V/9 W current consumption = approx. 0.75 A
24 V/9 W current consumption = approx. 0.38 A with pulse for indicator failure check

X	
----------	--

LED



E4 10176

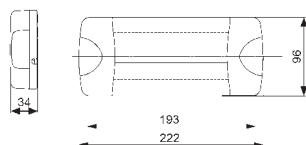

DuraLED Combi

for horizontal surface-mounting, clear-glass lens, with 40 LEDs and potted cable 2,500 mm long with stripped ends, multi-volt 8 – 28 V

Type approval	
ECE	SAE (USA)

2SD 959 050-401¹ ① ② ③

12 V/11 W current consumption = approx. 0.92 A
24 V/11 W current consumption = approx. 0.46 A with pulse for indicator failure check

X	
----------	--

LED



E1 2376

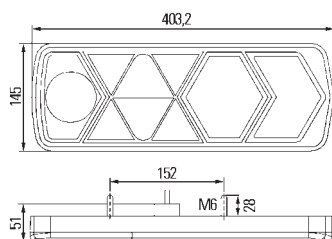

100% LED multi-function combination rearlight

for horizontal surface-mounting, tail-triangular reflector-stop-indicator-reverse light with cable 500 mm long and 7-pole EasyConn plug housing. All light functions using LED technology. Lens firmly glued to housing. With tail/stop light: 15 red LEDs, indicator: 15 amber LEDs, reverse light: 1 white LED, protective rating IP 6K9K.

Left-hand light with additional output from 7-pole EasyConn plug housing into a cable 500 mm long with 2-pole EasyConn receptacle housing for connection to a rear fog light.

left	2VP 340 950-011¹
------	------------------------------------

right only with 7-pole connection	2VP 340 950-021¹
-----------------------------------	------------------------------------

Taillight: 24 V/0.7 W current consumption = approx. 0.03 A

Stop light: 24 V/5 W current consumption = approx. 0.21 A

Indicator: 24 V/3 W current consumption = approx. 0.125 A

Reverse light: 24 V/5.5 W current consumption = approx. 0.23 A

Vertical version with rectangular reflector available on request.

Rear lighting



E4 10215

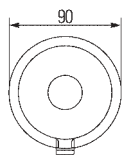

max. installation depth

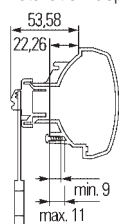

Combination rearlight Ø 90 mm

in a brilliant-finish design, mounting possible from the front using clips included loose or from the rear using screws, screw heads not visible, with pre-fitted 12 or 24 V bulbs, also available as daytime running light in 12 or 24 V (see page 23)

Reverse light and rear indicators with smoked glass lens

Type approval

ECE | SAE
(USA)

with mounting clips installed,
with pre-fitted 12 V bulbs

			Type approval	
			ECE	SAE (USA)
12 V	2SA 965 039-307	①	X	■ ●
12 V	2DA 965 039-317	②	X	■
12 V	2BA 965 039-347	③ rear	X	■
12 V	2NE 965 039-327	④	X	■ ●
12 V	2ZR 965 039-337²	⑤	X	■ ●

12 V	2SA 965 039-007	①	X	■ ●
12 V	2DA 965 039-017	②	X	■
12 V	2BA 965 039-027	③ rear	X	■
12 V	2NE 965 039-037	④	X	■ ●
12 V	2ZR 965 039-047	⑤	X	■ ●
12 V	2SB 965 039-057	① ②	X	■
24 V	2SA 965 039-087	①	X	■ ●
24 V	2DA 965 039-097	②	X	■
24 V	2BA 965 039-107	③ rear	X	■
24 V	2NE 965 039-117	④	X	■ ●
24 V	2ZR 965 039-127²	⑤	X	■ ●
24 V	2SB 965 039-137	① ②	X	■

E4 3919/7648



E4 6550

E4 23257

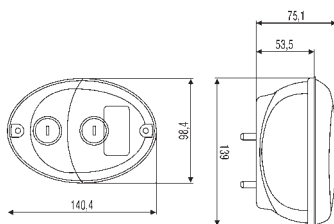

"Oval" combination rearlight – brilliant finish

suitable for horizontal and vertical flush-fitting and surface-mounting, can be used for 12 V and 24 V operation, before installation, break out the water drain hole and insert the seal, housing colour black, clear cover lens

Type approval

ECE | SAE
(USA)

2SB 343 130-027	① ②	X	■ ●
2BA 343 130-057	③	X	■ ●
2NE 343 130-037	④	X	
2ZR 343 130-047²	⑤	X	■ ●

Rear lighting



E4 10202

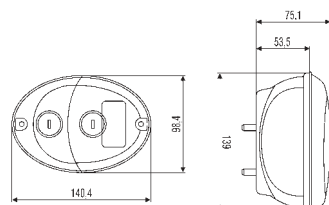

"Oval" combination rear light

as above, but with lens in brilliant-finish striped look

Type approval

ECE | SAE
(USA)

2SD 343 130-017	① ② ③	X	
------------------------	-------	---	--

■ SAE type approval for vehicles < 2,032 mm in width

● SAE type approval for vehicles > 2,032 mm in width

① Taillight

② Stop light

③ Indicator

④ Rear fog light

⑤ Reverse light

⑥ Reflector

⑦ Side marker light with reflector

⑧ Licence plate light

⑨ Parking light

¹ See the note on page 6 regarding LED light failure check.

² See the note on page 31

Rear lighting

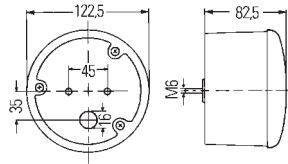

as adjacent versions, but without fastening screws



Type approval

ECE SAE (USA)

Part Number	Options	Code	ECE	SAE (USA)
2SB 964 169-717	① ②	815	X	■ ●
2NE 964 169-227	④	3808	X	■ ●
2BA 964 169-237	③ ④	648	X	■
2BN 964 169-247	③ ⑤	9801	X	■
2TA 964 169-257	① ② ⑥	9805	X	■
2SA 964 169-277	①	810	X	■ ●

Combination rearlight

for surface-mounting and flush-fitting, 12 and 24 V



Type approval

ECE SAE (USA)

Part Number	Options	Code	ECE	SAE (USA)
2DA 964 169-007	②	808	X	■ ●
2BA 964 169-017	③	648	X	■ ●
2NE 964 169-027	④	3808	X	■ ●
2ZR 964 169-037	⑤	2311	X	■ ●
2BA 964 169-047	③ ④	9804	X	
2BN 964 169-057	③ ⑤	9801	X	■
2TA 964 169-067	① ② ⑥	9805	X	■
2BE 964 169-077	Indicator / position light, front	9802	X	■
2SW 964 169-087	① ③	9803	X	■
2SA 964 169-097	①	810	X	■ ●
2ZR 964 169-107 ²	⑤	9903	X	■
2SD 964 169-117	① ② ③	-	X	
2SD 964 169-137	① ② ③	-		■
2TA 964 169-147	① ② ⑥	-		■
2SB 964 169-287	① ②	815	X	■ ●
2SW 964 169-167	① ③	-		■



E17 648/2311/3810/9805

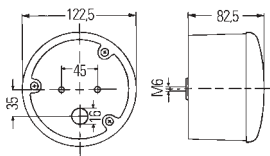

Combination rearlight

brilliant finish, for surface-mounting and flush-fitting, 12 and 24 V



Type approval

ECE SAE (USA)

Part Number	Options	Code	ECE	SAE (USA)
2BA 964 169-507	③	648	X	■ ●
2SB 964 169-537	① ②	9805	X	■ ●
2ZR 964 169-517 ²	⑤	2311	X	■ ●
2NE 964 169-527	④	3810	X	■ ●
as above, but without fastening screws				
2BA 964 169-647	③		X	■ ●
2SB 964 169-677	① ②		X	■ ●
2ZR 964 169-657	⑤		X	■ ●
2NE 964 169-667 ²	④		X	■ ●

LED



E4 23254

E17 814/3810

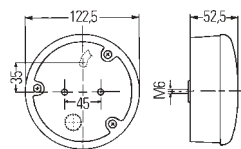

Combination rearlight

with 37 LEDs, for surface-mounting and flush-fitting



Type approval

ECE SAE (USA)

Part Number	Options	Code	ECE	SAE (USA)
2SB 964 169-307 ¹	① ②	814	X	
2NE 964 169-341 ¹	④	3810	X	



2ZR 964 169-351 ^{1, 2}	⑤ left	23254	X	
2ZR 964 169-361 ^{1, 2}	⑤ right	23254	X	

Tail/stop light: 24 V/5.7 W current consumption = approx. 0.24 A
 Rear fog light: 24 V/4 W current consumption = approx. 0.17 A
 Reverse light: 24 V/5 W current consumption = approx. 0.21 A

Rear lighting

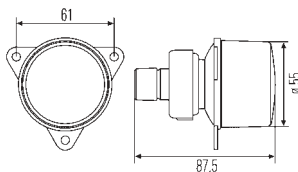

Combination rearlights

12 V and 24 V, for flush-fitting

① Taillight	2XA 008 221-021
with 12 V/5 W bulb fitted	2SA 008 221-127
① Stop light	2XA 008 221-021
with 12 V/21 W bulb fitted	2DA 008 221-167
② Indicator with smoked glass	2BA 008 221-041
with amber 12 V/21 W bulb fitted	2BA 008 221-147
③ Rear fog light	2NE 008 221-031
with 12 V/21 W bulb fitted	2NE 008 221-137
④ Reverse light with smoked glass	2ZR 008 221-051²
with 12 V/21 W bulb fitted	2ZR 008 221-157
Harness with grommet	8KA 152 134-007
Separate grommet	9GT 137 236-007

LED

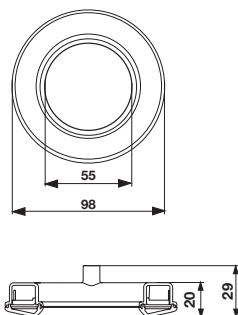
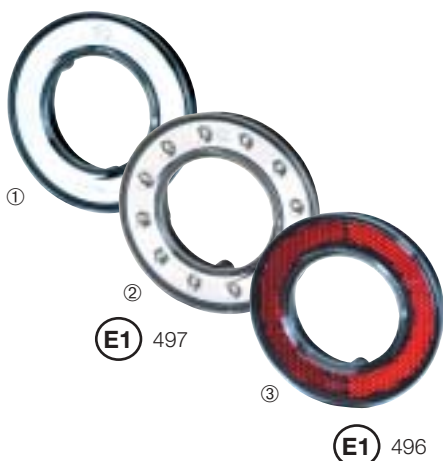

① Chrome-plated circular plate

for flush-fitting

8XU 008 405-031

② LED combined circular tail/clearance light

for flush-fitting

12 V **2SA 008 405-021¹**

24 V **2SA 008 405-011¹**

12 V/1.8 W current consumption = approx. 0.15 A

24 V/1.8 W current consumption = approx. 0.075 A

LED combined circular tail/stop light

12 V **2SB 008 405-101¹**

24 V **2SB 008 405-091¹**

12 V/2.1 W current consumption = approx. 0.175 A

24 V/2.1 W current consumption = approx. 0.0917 A

③ Circular reflector

for flush-fitting

8RA 008 405-001

Examples for combination possibilities

① Rear lighting **2BA 008 221-041**
and **2SA 008 405-021**

② Rear lighting **2XA 008 221-021**
and **8RA 008 405-001**

Accessories

Heat conducting shield (necessary

at ambient temperatures > 50 °C) **9XB 161 749-007**

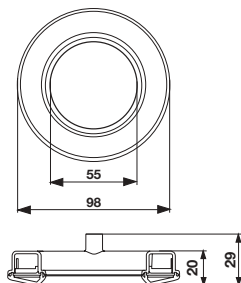

■ SAE type approval for vehicles < 2,032 mm in width

● SAE type approval for vehicles > 2,032 mm in width

① Taillight

② Stop light

③ Indicator

④ Rear fog light

⑤ Reverse light

⑥ Reflector

⑦ Side marker light with reflector

⑧ Licence plate light

⑨ Parking light

¹ See the note on page 6 regarding LED light failure check.

² See the note on page 31

Rear lighting

60 mm Premium lights



E4 3917/6546/7613/23255

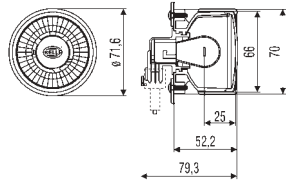

With pre-fitted 12 or 24 V bulbs			Type approval	
			ECE	SAE (USA)
12 V	2SA 009 001-047 ①	X		
12 V	2DA 009 001-057 ②	X		
12 V	2SB 009 001-067 ① ②	X		
12 V	2BA 009 001-007 ③	X		
12 V	2BA 009 001-191 ③	X		
with Silver Vision bulb				
12 V	2NE 009 001-027 ④	X	■	
12 V	2ZR 009 001-017² ⑤	X	■	
24 V	2SA 009 001-137	X		
24 V	2DA 009 001-147	X		
24 V	2SB 009 001-157	X		
24 V	2BA 009 001-107	X		
24 V	2NE 009 001-127	X	■	
24 V	2ZR 009 001-117²	X	■	
8RA 009 001-037 ⑥ Macro reflector			X	■

Macro reflector



E4 3189

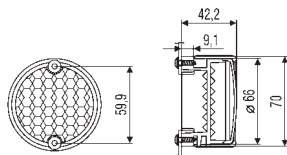

LED

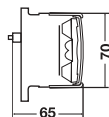

12 Power Topled LEDs			Type approval	
			ECE	SAE (USA)
12 V	2SB 009 001-401¹ ① ②	X		
12 V	2BA 009 001-411¹ ③	X		
24 V	2SB 009 001-501¹ ① ②	X		
24 V	2BA 009 001-511¹ ③	X		

Taillight: 0.4 W

Stop light: 2.6 W

Indicator: 1.5 W

not in connection with design ring Ø 71.6 mm



Design ring Ø 71,6 mm

Suitable for 60 mm light modules with a diameter of 71.6 mm.

(Part number ... 009 001-...),

one "click" is all it takes for a perfect high-sheen finish

high-sheen chrome-plated	9HB 161 122-012
silver	9HB 161 122-007
Premium silver	9HB 164 168-002



Combination example of a combination rearlight 009 001 with a high-sheen chrome-plated design ring,

not in connection with design ring Ø 71,6 mm

Rear lighting

Ring modules and accessories for 60 mm Premium lights

LED

Available either with a clear-glass or red cover lens

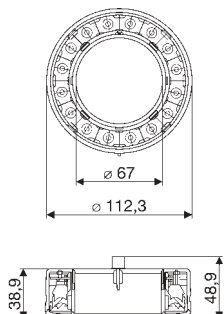

E4 7747



Combination example with macro reflector, ring module and design ring

Type approval

Ring module, 12 V

		Type approval	
		ECE	SAE (USA)
12 V	2SB 009 362-041¹	① ② red lens	X
12 V	2SB 009 362-021¹	① ② clear-glass lens	X
	8RA 009 362-001¹	⑥ red lens	X
24 V	2SB 009 362-011¹	① ②	X

12 V-tailight = 0.1 W

12 V-stop light = 2.3 W

24 V-tailight = 0.2 W

24 V-stop light = 4.6 W

Ring module without light function

for setting up, optically symmetrical light units

red lens	8XU 009 362-101
clear-glass lens	8XU 009 362-111

Design ring Ø 118 mm

suitable for ring module 009 362, available either with a perfect high-sheen finish or silver-coloured with a "click"

high-sheen chrome-plated	9HB 163 085-012
silver	9HB 163 085-001

Superseal connection plug, 3-pole

10 jack housings	8JA 746 184-032
50 jack contacts 1.0 – 1.5 mm	8KW 744 837-002
50 strand insulations 1.8 – 2.4 mm	9GD 746 185-002

Accessories for 60 mm combination rearlights



Adapter ring to be screwed in place from the front

for combination rearlights Ø 60 mm

Direct mounting and mounting in the ring module

① black **9XD 161 119-007**

Adapter ring

for mounting LED lights or the reflector in the ring module

black (not illustrated) **9XD 161 119-017**



Locking ring for front-end installation

suitable for bulb and LED version

silver-coloured **8HG 162 530-007**



Counter-plug set for 20 lights

2-pole **8JD 156 150-807**

Counter-plug set for 20 lights

3-pole (not illustrated) **8JD 162 581-802**

■ SAE type approval for vehicles < 2,032 mm in width

● SAE type approval for vehicles > 2,032 mm in width

- ① Taillight
- ② Stop light
- ③ Indicator
- ④ Rear fog light
- ⑤ Reverse light
- ⑥ Reflector
- ⑦ Side marker light with reflector
- ⑧ Licence plate light
- ⑨ Parking light

¹ See the note on page 6 regarding LED light failure check.

² See the note on page 31

Rear lighting

LED



E13 0515

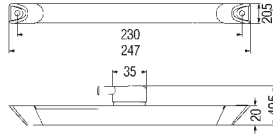

Clearance light

with 2 LEDs and light guide strip in red,
for vertical or horizontal surface-mounting

12 V **2XS 008 078-011¹**

24 V **2XS 008 078-001¹**

12 V/0.7 W current consumption = approx. 0.06 A

24 V/1.4 W current consumption = approx. 0.06 A



E1 1201

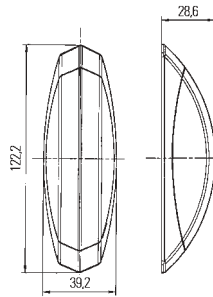

Clearance light

for vertical surface-mounting with grey base plate

left, with 12 V/5 W bulb **2XS 008 479-001**

right, with 12 V/5 W bulb **2XS 008 479-011**

left, with 24 V/5 W bulb **2XS 008 479-041**

right, with 24 V/5 W bulb **2XS 008 479-051**

left, without bulb **2XS 008 479-061**

right, without bulb **2XS 008 479-071**

with white base plate

left, with 12 V/5 W bulb **2XS 008 479-081**

right, with 12 V/5 W bulb **2XS 008 479-091**

LED



E17 0302

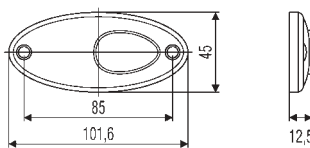

Clearance light

with 2 LEDs, for horizontal surface-mounting, with reflector,

12 V **2TM 964 295-107¹**

24 V **2TM 964 295-097¹**

12 V/0.5 W current consumption = approx. 0.04 A

24 V/1.0 W current consumption = approx. 0.04 A



E1 31468

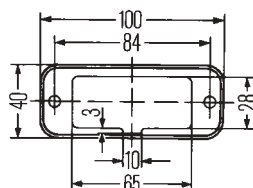

Clearance light

without reflector **2SA 961 167-011**

Rear lighting

LED



E1 1395/1398

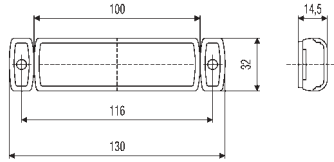

Clearance light

with reflector, for vertical or horizontal surface-mounting

Cable 500 mm **2TM 008 645-061¹**

Cable 5,000 mm **2TM 008 645-071¹**

24 V/1.2 W current consumption = approx. 0.05 A

Rubber seal

(order separately) **9GD 157 867-007**



E4 7507

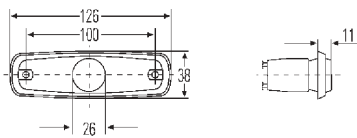

Clearance light

with pre-fitted 24 V/5 W bulb,
for horizontal flush-fitting

without reflector **2SA 962 964-091**

Seal (please order separately) **9GD 963 281-001**

Grommet (please order separately) **9GT 963 129-001**

LED



E4 7574

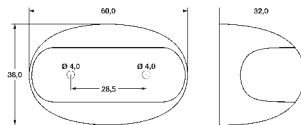

Clearance light

in LED technology for horizontal surface-mounting

with 500 mm cable, 8 V – 28 V **2XA 959 560-401¹**

with 5,000 mm cable, 8 V – 28 V **2XA 959 560-411¹**

12 V/0.5 W current consumption = approx. 0.04 A

24 V/0.5 W current consumption = approx. 0.02 A

LED

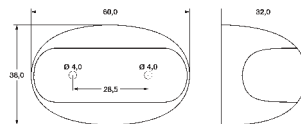

Clearance light, red

in LED technology, 12 V,

with 500 mm cable

for horizontal surface-mounting

2PS 959 660-407¹

12 V / 0.5 W, current consumption = approx. 0.04 A

Type approval

ECE | **SAE**
(USA)



■ SAE type approval for vehicles < 2,032 mm in width

● SAE type approval for vehicles > 2,032 mm in width

① Taillight ② Stop light ③ Indicator
⑥ Reflector ⑦ Side marker light with reflector

④ Rear fog light ⑤ Reverse light
⑧ Licence plate light ⑨ Parking light

¹ See the note on page 6 regarding LED light failure check.

Rear lighting

LED



E17 9808

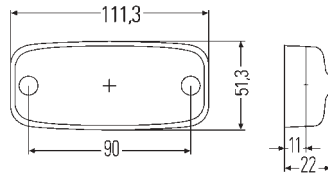

Clearance light

with 2 LEDs, reflector and cable 5,000 mm long

12 V **2TM 963 639-307¹**

24 V **2TM 963 639-317¹**

12 V/0.5 W current consumption = approx. 0.04 A

24 V/1.0 W current consumption = approx. 0.04 A

LED



E13 0531

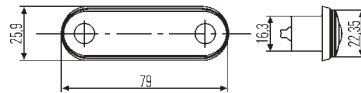

Clearance light

with 2 red LEDs, for horizontal and vertical flush-fitting

with 500 mm cable, 8 V – 28 V **2XA 959 790-401¹**

with 5,000 mm cable, 8 V – 28 V **2XA 959 790-411¹**



E1 3190

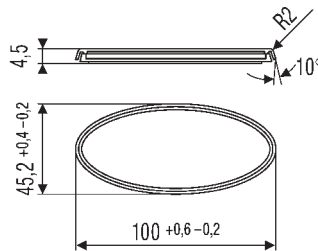

Oval reflector

with adhesive attachment

red **8RA 343 160-007**

amber **8RA 343 160-027**

white **8RA 343 160-017**



E1 22871

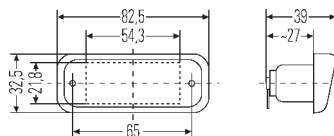

Licence plate light

for flush-fitting above or to the left and right of the licence plate

24 V **2KA 005 049-017**

Available as LED version from 2nd quarter 2008

Rear lighting

LED



(E4) 7715

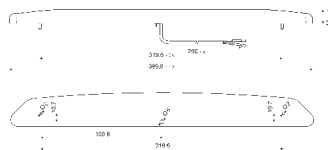

Safety stop light

for horizontal surface-mounting,
with 12 red LEDs, in brilliant finish with 3D effect
due to each LED being embedded in a separate reflector,
with cable 200 mm long, red lens

12 V	2DA 343 800-007¹
12 V, with rubber base	2DA 343 800-057¹
24 V, screw version	2DA 343 800-047¹

12 V/1.8 W current consumption = approx. 0.15 A
24 V/1.8 W current consumption = approx. 0.08 A

Safety stop light in combination with
rear view camera, see page 53

LED



(E4) 7547

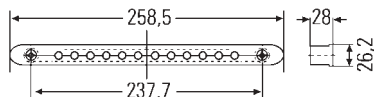

Safety stop light

for horizontal flush-fitting,
with 12 red LEDs and connected supply cable

12 V, red lens	2DA 959 071-537¹
24 V, red lens	2DA 959 071-737¹
12 V, clear-glass lens	2DA 959 071-037¹
24 V, clear-glass lens	2DA 959 071-237¹

12 V/2 W current consumption = approx. 0.17 A
24 V/2 W current consumption = approx. 0.08 A

LED



(E4) 7696

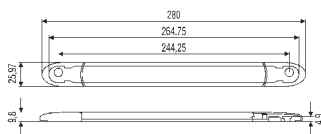

Safety stop light

for horizontal or vertical surface-mounting, with 10 red LEDs,
with cable 3,000 mm long, installed height 9 mm

with screw attachment

12 V, red lens	2DA 343 106-007
24 V, red lens	2DA 343 106-011
12 V, with smoked glass lens	2DA 343 106-021
24 V, with smoked glass lens	2DA 343 106-031

self-adhesive (for smooth and clean surfaces)

12 V, red lens	2DA 343 106-207
24 V, red lens	2DA 343 106-211
12 V, with smoked glass lens	2DA 343 106-221
24 V, with smoked glass lens	2DA 343 106-231

12 V/0.7 W current consumption = approx. 0.06 A
24 V/1.4 W current consumption = approx. 0.06 A

- SAE type approval for vehicles < 2,032 mm in width
- SAE type approval for vehicles > 2,032 mm in width

- ① Taillight
- ② Stop light
- ③ Indicator
- ④ Rear fog light
- ⑤ Reverse light
- ⑥ Reflector
- ⑦ Side marker light with reflector
- ⑧ Licence plate light
- ⑨ Parking light

¹ See the note on page 6 regarding LED light failure check.

LED

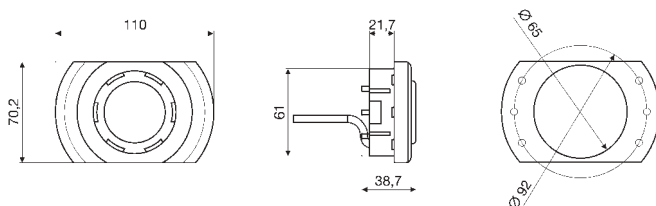
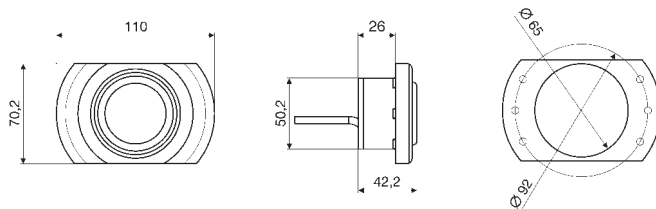

Spot LED Oval

1 white LED, black housing, clear lens with matt edging, electrical connection through a cable 200 mm long, multi-volt 9-31 V, narrow illumination, possible to change between white functional lighting and ambient blue or red night design

Screw installation, flush-fitting, fix Black trim*

with blue, ambient Celis® ring

2JA 343 680-177

without Celis® ring

2JA 343 680-157

White trim*

with blue, ambient Celis® ring

2JA 343 680-077

without Celis® ring

2JA 343 680-057

Grey trim*

with blue, ambient Celis® ring

2JA 343 680-127

with white, ambient Celis® ring

2JA 343 680-047

without Celis® ring

2JA 343 680-007

Screw or spring installation, flush-fitting, adjustable (swivelling angle 20 degrees)

Black trim*

with blue, ambient Celis® ring

2JA 343 700-271

without Celis® ring

2JA 343 700-251

White trim*

with blue, ambient Celis® ring

2JA 343 700-227

without Celis® ring

2JA 343 700-207

Grey trim*

with blue, ambient Celis® ring

2JA 343 700-127

without Celis® ring

2JA 343 700-107

Screw installation, flush-fitting, adjustable (swivelling angle 20 degrees)

Black trim*

with red, ambient Celis® ring

2JA 343 700-167

Ambient Celis® ring

12 V/1 W current consumption = approx. 0.06 A

24 V/1 W current consumption = approx. 0.03 A

Spot

12 V/2.5 W current consumption = approx. 0.18 A

24 V/2.5 W current consumption = approx. 0.09 A

* further trim colours on request

LED

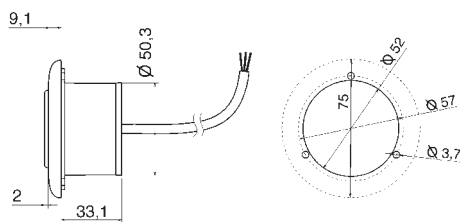

Spot LED Round

1 white LED, black housing, clear lens with matt edging, electrical connection through a cable 200 mm long, multi-volt 9-31 V, narrow illumination, possible to change between white functional lighting and ambient blue or red night design

Screw installation, flush-fitting, fixed (not illustrated)

Black trim*

with blue, ambient Celis® ring

2JA 343 980-117

with white, ambient Celis® ring

2JA 343 980-217

White trim (not illustrated)

with blue, ambient Celis® ring

2JA 343 980-107

with white, ambient Celis® ring

2JA 343 980-207

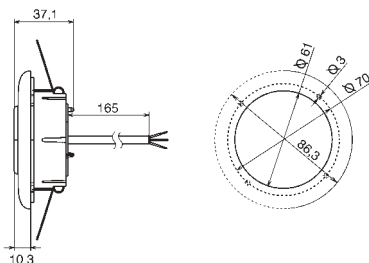

Screw or spring installation, flush-fitting, adjustable (swivelling angle 20 degrees)

Black trim*

with blue, ambient Celis® ring

2JA 343 790-117

with white, ambient Celis® ring

2JA 343 790-217

White trim (not illustrated)

with blue, ambient Celis® ring

2JA 343 790-107

with white, ambient Celis® ring

2JA 343 790-207

Ambient Celis® ring

12 V/1 W current consumption = approx. 0.06 A

24 V/1 W current consumption = approx. 0.03 A

Spot

12 V/2.5 W current consumption = approx. 0.18 A

24 V/2.5 W current consumption = approx. 0.09 A

* further trim colours on request



(LED version illustrated)

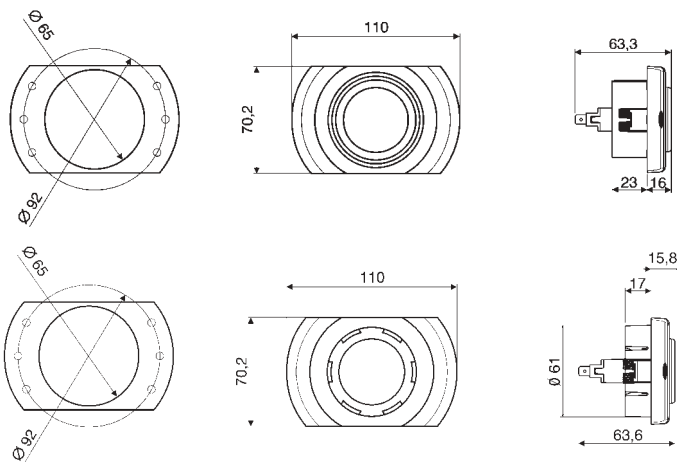

Spot-Bulb Oval

Screw and spring installation, flush-fitting, fixed
with 24 V bulb

Black trim (illustration similar)

2JA 343 860-067

White trim (illustration similar)

2JA 343 860-077

Screw and spring installation, flush-fitting, adjustable
with 24 V bulb

Black trim (illustration similar)

2JA 343 865-067

White trim (illustration similar)

2JA 343 865-077

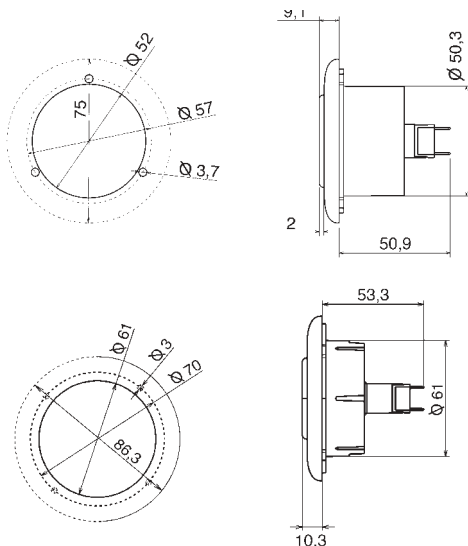

Spot-Bulb round

Screw installation, flush-fitting, fix
with 24 V bulb

Black trim

2JA 343 985-057

White trim

2JA 343 985-047

Screw and spring installation, flush-fitting, adjustable
with 24 V bulb

Black trim

2JA 343 795-157

White trim

2JA 343 795-147

LED

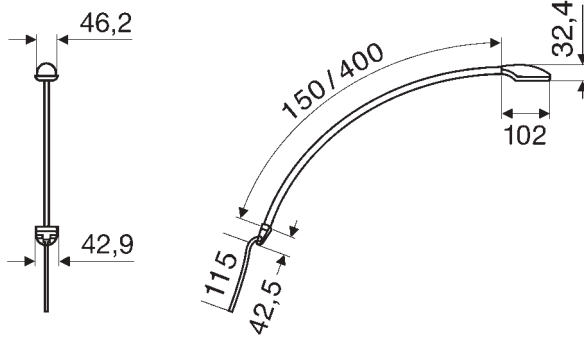

Reading light

for surface-mounting, flexible arm
1 white LED, patterned lens, electrical connection through a cable 115 mm long, multi-volt 9 – 31 V, narrow illumination, excellent for map-reading

Black trim*

flexibly adjustable arm

150 mm	2JA 343 720-021
400 mm	2JA 343 720-121

White trim*

flexibly adjustable arm

150 mm	2JA 343 720-011
400 mm	2JA 343 720-111

12 V/2.5 W current consumption = approx. 0.20 A

24 V/3 W current consumption = approx. 0.12 A

* further trim colours on request

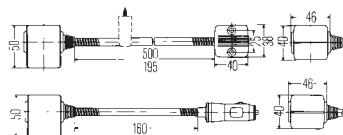

Spot reading lights

powerful, glare-free light source with flexible metal arm, with holder for fixed installation, incl. halogen bulb 12 V / 5 W (24 V version on request)

for fixed installation

500 mm long	2AB 004 532-001
-------------	-----------------

for fixed installation

195 mm long	2AB 004 532-011
-------------	-----------------

with plug for cigarette lighter

160 mm long	2AB 004 532-021
-------------	-----------------

LED

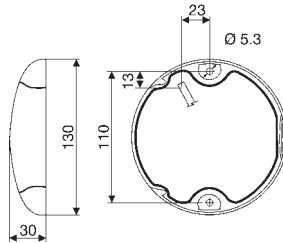

EuroLED

for surface-mounting, cast in one piece with the base plate, 1 white LED, clear lens, electrical connection through a cable 2,500 mm long, multi-volt 9 – 33 V

2JA 959 820-501

12 V/2.5 W current consumption = approx. 0.21 A

24 V/2.5 W current consumption = approx. 0.10 A

LED

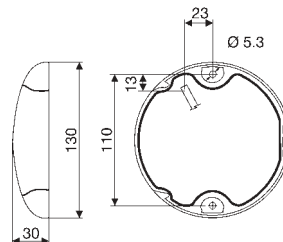

EuroLED Touch

for surface-mounting, cast in one piece with the base plate, 1 white and 8 red LEDs, clear lens, electrical connection through a cable 2,500 mm long, multi-volt 9 – 33 V, with sensitive switch, for switching on/off and dimming and changing between white and red light

black cover trim **2JA 959 950-031**

white cover trim **2JA 959 950-041**

12 V/3 W current consumption = approx. 0.25 A

24 V/3 W current consumption = approx. 0.13 A

LED

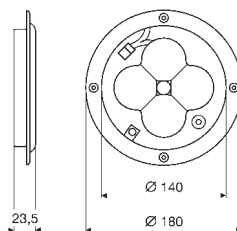

CargoLED

for flush-fitting, 4 white LEDs, clear-glass lens and aluminium installation frame, electrical connection through cable 310 mm long, cable with stripped ends, multi-volt 9 – 31 V, wider illumination at close range, ADR/GGVS tested, IP 69, temperature range -40 °C to +60 °C

white functional lighting **2JB 343 227-001**

ambient functional lighting **2JB 343 227-047**

12 V/6 W current consumption = approx. 0.46 A

24 V/6 W current consumption = approx. 0.22 A

LED

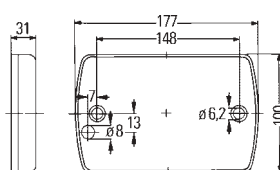

DuraLED

for surface-mounting, cast in one piece with white base plate, 36 white LEDs, clear-glass lens and white housing, electrical connection through a cable 2,500 mm long, multi-volt 9 – 33 V, wide horizontal and narrow vertical illumination

2JA 959 037-511

12 V/9 W current consumption = approx. 0.75 A

24 V/9 W current consumption = approx. 0.38 A

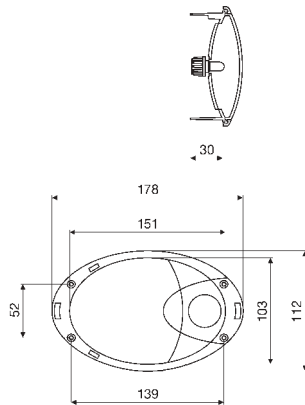

Ceiling light

for flush-fitting, 6 W bulb, broad illumination, warm white light, transparent lens, black housing, connection through blade connector, screw or snap-on attachment possible, IP 3, temperature range -40 °C to +60 °C

Filament bulb

2JA 009 294-001

Reading spotlight, narrow illumination

2JA 009 294-021

12 V/6 W current consumption = approx. 0.5 A

LED

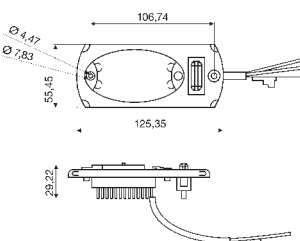
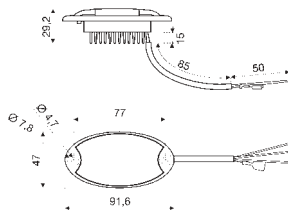
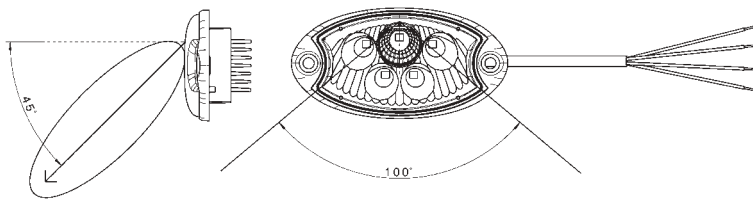

Mini OvalLED

for flush-fitting, 4 white LEDs, 1 red LED, brilliant-finish clear lens, black housing, ambient lighting can be switched on in addition, illumination for the driver or instrument panel area at the side, IP69, temperature range -40 °C to +60 °C

blue ambient, without frame and switch

Premium G-LED **2JA 343 570-107**

Standard E-LED **2JA 343 570-127**

blue ambient, with frame and switch

Premium G-LED **2JA 343 570-147**

Standard E-LED **2JA 343 570-167**

red ambient, without frame and switch

Premium G-LED **2JA 343 570-007**

Standard E-LED **2JA 343 570-027**

red ambient, with frame and switch

Premium G-LED **2JA 343 570-047**

Standard E-LED **2JA 343 570-067**

24 V/6 W current consumption = approx. 0.25 A

LED

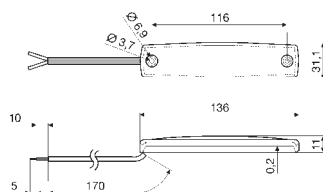

Mini ThinLED

for surface-mounting, cast in one piece with the grey base plate, clear lens, electrical connection through a cable 170 mm long, broad illumination at close range, IP 69, temperature range -40 °C to +60 °C

5 white LEDs **2JA 343 660-101**

3 white LEDs **2JA 343 660-007**

3 blue LEDs **2JA 343 660-027**

3 green LEDs **2JA 343 660-061**

24 V/0.7 W current consumption = approx. 0.03 A

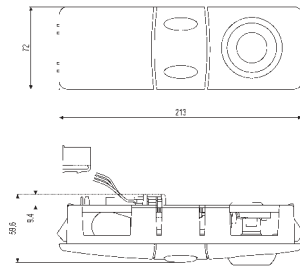

Compact light

for surface-mounting, halogen bulbs, movable spotlight, clear lens, with cable 500 mm long, grey switch and housing

12 V	2JA 009 037-017
24 V	2JA 009 037-027

Spot

12 V/10 W current consumption = approx. 0.83 A
 24 V/10 W current consumption = approx. 0.42 A

Filament bulb

12 V/21 W current consumption = approx. 1.75 A
 24 V/21 W current consumption = approx. 0.86 A

LED

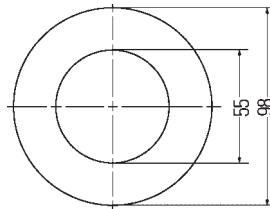

Compact light

for flush-fitting, 12 LEDs, clear lens

white LEDs	2PF 008 405-061
blue LEDs	2JA 008 405-081
12 V/1.8 W current consumption = approx. 0.15 A	

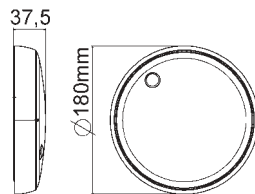

Transistor ceiling light

for surface-mounting, multi-volt 10 – 30 V, white lens, white housing, splashwater-proof, with excess and undervoltage protection, incl. light sources 7W 2G7

with switch	2JA 998 565-011
without switch	2JA 998 565-031

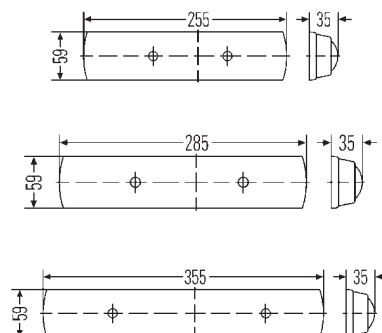

Transistor ceiling light

for surface-mounting, clear-glass lens, with switch, compact fluorescent light, full interference suppression

255 mm long	2JA 007 373-011
24 V/7 W current consumption = approx. 0.3 A	
285 mm long	2JA 007 373-041
24 V/9 W current consumption = approx. 0.38 A	
355 mm long	2JA 007 373-071
24 V/11 W current consumption = approx. 0.45 A	

LED

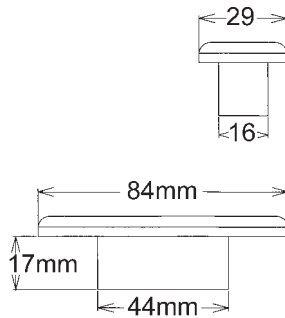

Step light, emergency and night-lighting

for flush-fitting, 2 LEDs, clear-glass lens, seal, fastening screws and screw caps, dustproof and waterproof, with polarity inversion protection, multi-volt 10 – 33 V

electrical connection through a cable 120 mm long

white LEDs **2XT 959 510-427**

blue LEDs **2XT 959 510-657**

electrical connection through a cable 150 mm long and 2-pole Packard plug

white LEDs **2XT 959 510-467**

12 V/0.35 W current consumption = approx. 0.03 A

24 V/0.7 W current consumption = approx. 0.03 A

LED

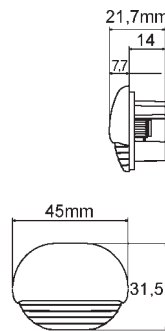

Step light

for flush-fitting, 1 LED, clear lens, electrical connection through a potted cable 100 mm long, white cover cap seal, installation possible using 2 screws or with snap-on attachment, broad illumination at close range

white LED **2JA 998 560-017**

blue LED **2JA 998 560-057**

12 V/0.5 W, current consumption = approx. 0.04 A

white LED **2JA 998 560-037**

blue LED **2JA 998 560-077**

24 V/0.5 W current consumption = approx. 0.02 A

LED

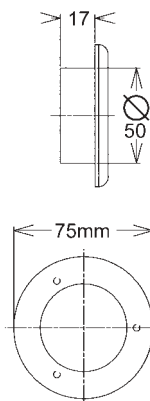

Step light, cockpit or map-reading light, emergency and night-lighting

for flush-fitting, 4 LEDs, clear glass lens, with white ring for covering the 3 fastening screws, with cable 120 mm long, seal and fastening screws, dustproof and waterproof, with polarity inversion protection, multi-volt 10 – 33 V

white LEDs **2XT 959 500-677**

blue LEDs **2XT 959 500-207**

12 V/0.7 W current consumption = approx. 0.06 A

24 V/1.4 W current consumption = approx. 0.06 A

LED

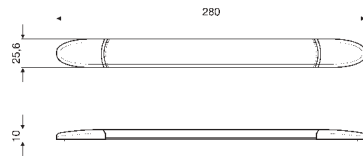

Step light

for surface-mounting, cast in one piece with the grey base plate, 10 white LEDs, clear lens, grey cover caps, electrical connection through a cable 500 mm long, broad illumination at close range, IP 69, temperature range -40 °C to +60 °C

2JA 343 606-007

12 V/1.8 W current consumption = approx. 0.15 A

2JA 343 606-017

24 V/3.6 W current consumption = approx. 0.15 A

LED

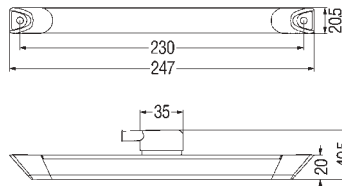

Step light

for surface-mounting, welded to base plate, clear-glass lens, grey housing, for horizontal or vertical surface-mounting, electrical connection through blade connector and grommet, with prism rod as light aperture body

2 white LEDs

2JA 008 078-031

2 blue LEDs

2JA 008 078-021

12 V/1.8 W current consumption = approx. 0.12 A

LED

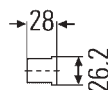
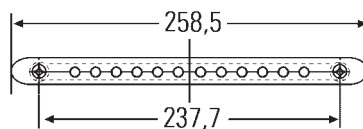

Step light

for flush-fitting, cast in one piece, 10 white LEDs, clear-glass lens, cable 2,500 mm long, with screws, screw caps, seal and cable clips

2JA 959 073-001

12 V/2 W current consumption = approx. 0.17 A

2JA 959 073-201

24 V/2 W current consumption = approx. 0.09 A

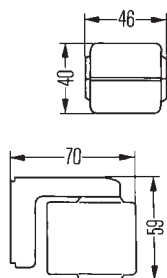

Reading light

for surface-mounting, halogen bulb, white lens, black housing, integrated on/off switch in the light head, can be rotated (340°) and swivelled (330°), cable 250 mm long, with replaceable red lens

2AB 004 532-102

12 V/5 W current consumption = approx. 0.42 A

Xenon

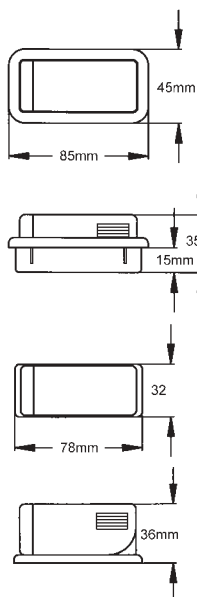

Reading light

for flush-fitting/surface-mounting, xenon gas discharge light, black housing with high-sheen vapour-plated aluminium reflector, electrical connection through a cable 100 mm long, switch on/off by lifting the light head, light can be rotated (340°) and vertically adjusted

Flush-fitting without screws, with retaining spring

2AB 004 813-072

Surface-mounting, incl. mounting screws

2AB 004 813-082

12 V/6 W, current consumption = approx. 0.5 A

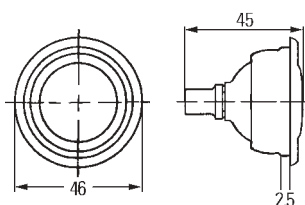

Reading light

for flush-fitting, bulb, clear-glass lens, black housing, electrical connection through two cables 120 mm long, adjustable light head

2AB 004 074-027

12 V/5 W current consumption = approx. 0.42 A

New dimensions in the field of electrics and electronics



Electronic components are becoming more and more important all the time: They are the little helpers that, although not obvious, make bus drivers' lives easier and take over lots of things automatically.

Hella covers the whole wide range of possibilities: from state-of-the-art standard solutions through to individual application developments. Additionally, we remain true to our motto "More safety and more convenience" in this area, too. Hella offers the combination of safety stop light and rear view camera in one solution (see page 53) as well as applications for closing aids and locking fixtures for storage cabin flaps and caravan doors. Also new: The switch generation with 6,000 possible lasering and lighting possibilities (see page 54).

Rain/light sensor

The rain/light sensor increases driver comfort as well as safety in road traffic. In twilight situations in particular, automatic switching of the vehicle lighting significantly improves drivers' visibility, enabling them to perceive other road users and situations sooner and more attentively. A further advantage of the rain/light sensor is the automatic increase in wiping processes, in particular when heavy rain sets in. The driver's view is clearly improved and contributes to traffic safety.

Both the rain sensor and light sensor are combined in one device. The sensor is fastened to the windscreen by means of a retaining ring.

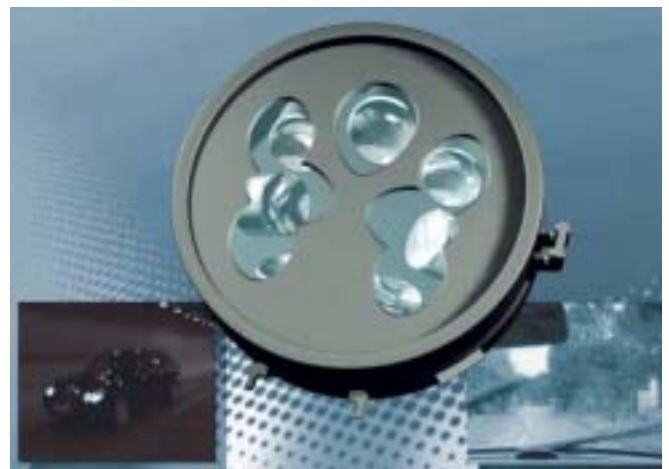

Rear view camera system RVS-1 ... see what's behind.

- Minimum dimensions
(W x H x D with hoop: 56 x 47 x 38 mm)
- Is activated automatically when the vehicle is put into reverse gear
- Extremely large visible range: 92° vertical and 120° horizontal
- High night vision ability
- Extremely resistant to vibrations
- High temperature resistance: -40 °C to +85 °C
- Variable surface-mounting possibilities
- Compact TFT monitor with diagonal screen size 12.6 cm.
Also suitable for connection to other video sources (DVD, DVB-T etc.).
- High-quality, digital image recording: 1/3-inch CMOS with 250,000 Pixels
- In many cases, the camera can also be connected to a display already mounted in the vehicle.
- Image signal: NTSC
- All the components comply with the high quality requirements of the automotive industry.



Representation of the situation behind



For coaches ...

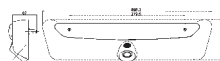
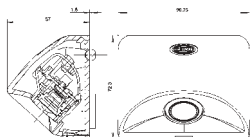
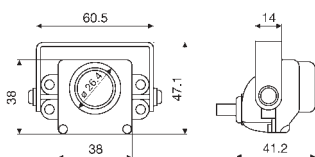

Rear view camera system RVS-1

Scope of supply: High-quality rear view camera RVC-1, incl. 5 inch TFT monitor in absolutely top quality 10 m professional harness and installation material.*

5BD 009 690-001

Monitor: e1 034873

Rear view camera RVC-1

incl. installation material

5BD 166 175-001

Camera: e1 034874

*Optionally available:

Cinch cable adapter

for camera **8KB 169 080-001**

for monitor **8KB 169 079-001**

10 m supplementary harness

8KB 166 530-001

Installation housing for

RVC-1 solo

9BG 169 974-001

(order camera separately)

RVC-1 in combination with CHMSL

Housing **9BG 169 975-001**

(order camera and light separately)

A voltage reduction device is necessary for 24 V:

8ES 006 658-001

(additional cable to the camera necessary)

New module switch generation: Micro-switches



Advantages

■ Enhanced power efficiency:

The increasing number of electronic control components puts a large strain on the vehicles' power system. Since it is very costly to supply the required power, there is a noticeable trend towards very low control currents which still need to be reliably switched. Our solution: a system of snap-action friction switches and chosen pairs of mating contacts. The standard AgNi version reliably makes or breaks contacts under as low as mA loads.

Equally, particularly efficient Power LEDs are another means of reducing power requirements by up to 70 % per switch compared to previous switch ranges.

■ Maintenance-free:

Operators expect the switch to work reliably and without maintenance throughout the vehicle's entire life cycle. Key influencing parameters are the expected life (cycles) of the contacts and the expected life of the light source. We provide our customers with our particularly wear-resistant "micro-switch system". Its snap-action friction switch minimises wear and contamination of contact faces with every flick of the switch. The average expected life of each LED is up to 100,000 h.

Technical data

Material, rocker, 2-comp.:	PC transparent and white
Material, base:	PA black
Terminal contacts:	3 mm Junior Power Timer
Light source:	max. 4 LEDs: 2 x orientation lighting, green 2 x functional lighting, red
Symbol type:	lasered
Service life:	5mA 450,000 cycles 5 A/24 V inductive, 270,000 cycles 4 A/24 V lamp, 90,000 cycles 10 A/24 V resistive, 80,000 cycles
Impermeability:	IP30
Operating temperature:	-35 °C to +85 °C
Storage temperature:	-40 °C to +100 °C
Dashboard depth:	2 mm (direct installation)
Accessories:	<ul style="list-style-type: none"> ■ Single mounting frame: 9AR 168 396-001/-007 ■ Modular mounting frame: <ul style="list-style-type: none"> End frame, left: 9AR 169 209-001/-007 Middle frame: 9AR 169 208-001/-007 End frame, right: 9AR 169 210-001/-007 ■ Connector skirt: 8JD 010 076-001/-007

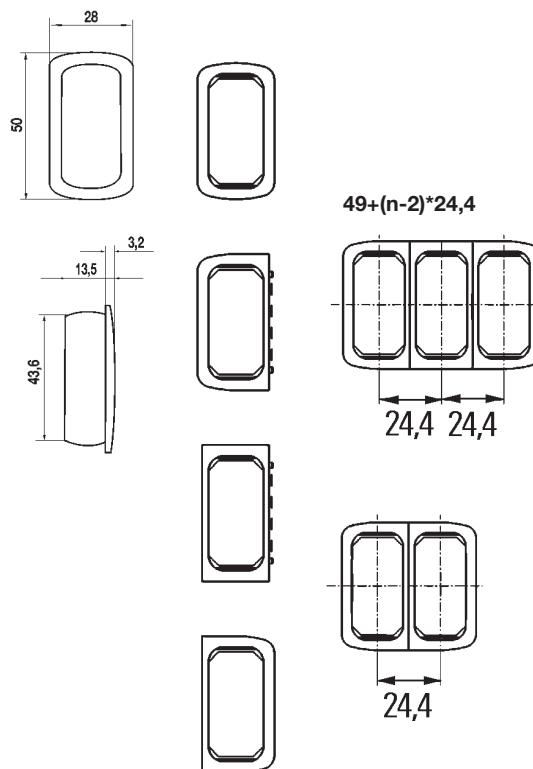

For further information and details on ordering, please follow the link www.hella.de/modulschalter or www.hella.com/rockerswitch or refer to Hella's Electrics Catalogue 2007/2008.

Rocker switches

The Hella switch series "4570" and "7832" can be used universally for all vehicle categories.

See the Hella Electrics Catalogue 2007/2008 for the complete range.



DIN
40050

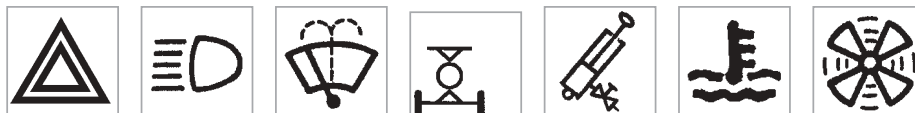

Advantages

- Holder with LED, can be used for 12 – 32 V
- Simple conversion from previous bulb holders to LED socket
- Only one LED for orientation and functional lighting
- Long LED service life
- Resistant to knocks and vibration
- Minimum energy consumption
- Low heat development

Holder with LED **9FF 713 627-031**

Technical data

Operating voltage:	12 V	24 V
Switching power:	20 mA to 0 mA to	16 A at 12 V 8 A at 24 V
Protective rating:	Suitable for the interior acc. to IP 6X DIN 40050	
Operating temperature:	-35 °C to +65 °C	
Service life:	250,000 switching processes	
Switch versions:	one-stage	(0- 1)
	two-stage	(0- 1- 2)
	One-sided switch	
	Two-sided switch	
	Lock	
Housing:	Plastic, black grained	
Maximum load capacity:	12 V 16 A; 24 V 8 A	
Electrical installation:	Blade terminal connections 6.3 mm, DIN 46244	
Installation:	Can be clicked into place in sized installation openings or time-saving mounting frames	
	8HG 713 626-001 (6 switches) or	
	8HG 714 504-001 (3 switches)	
	Dashboard depth 1-2.5 mm	
Installation depth:	45 mm;	
	when using receptacle housing	
	8JA 713 631-001	60 mm
Weight:	25 - 30 g; depending on version	

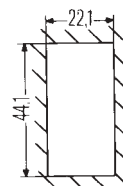
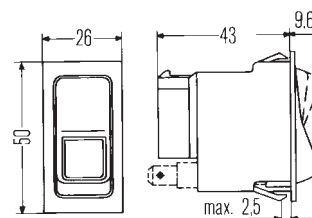

Model series 4570

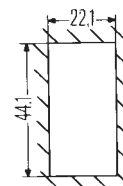
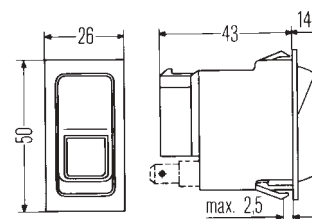

Model series 7832

The Hella mirror range



The wide range for:

- Main mirrors
- Wide angle mirrors
- Ramp mirrors
- Complete mirror systems

The mirror range covers a multitude of vehicles, from buses, transporters, trucks through to agricultural and construction machinery. A wide range of spare parts rounds off the range.

Coachline® – the brand-new modular mirror system for buses with an innovative design for a distinctive appearance. Standard basic range with different sets for all bus types.

Bus mirror series Coachline® modular system with different sets.

Mirror head and mirror arm both made of black plastic, can be painted

Mirror set main mirror (1) Dimensions: 259 x 804 mm

left **8SB 501 431-871**

right **8SB 501 431-881**

Mirror set main mirror + combined mirror (1, 2)

Dimensions: 264 x 988 mm

left **8SB 501 431-851**

right **8SB 501 431-861**

Mirror set main mirror + wide angle mirror (1, 3)

Dimensions: 264 x 988 mm

left **8SB 501 431-831**

right **8SB 501 431-841**

Mirror set main mirror + combined mirror +

wide angle mirror (1, 2, 3) Dimensions: 269 x 1230 mm

left **8SB 501 431-811**

right **8SB 501 431-821**

Spare parts

Mirror glass base 24 V, for main mirror

9MX 562 841-002

Mirror glass base 24 V, for combined mirror

left **9MX 564 357-011**

right **9MX 564 357-002**

Mirror glass base 24 V, for wide angle mirror

9MX 562 846-031

upper/lower Cover cap

long **9HD 564 945-002**

short **9HD 564 946-002**

II e1 02* 0369

IV e1 03* 0040



Coach mirrors

Mirror head made of black/grey plastic,

Mirror head: 479 x 210 mm, mirror glass: 400 x 165 mm,

Curved radius: 1800 mm

Mirror head made of black/grey plastic,

Driving mirror: 340 x 175 mm, combined mirror

(observation of the rear and entry doors):

188 x 134 mm

II e1 02* 0566

II e1 03* 0108

Wing mirror left (1) for EvoBus (Mercedes-Benz)

Citaro, EvoBus (Setra) Kombibus

8SB 501 401-802

Wing mirror right (1) for EvoBus (Mercedes-Benz)

Citaro (length of mirror arm: 687 mm)

8SB 501 402-802

Wing mirror right (1) for EvoBus (Setra) Kombibus

(length of mirror arm: 633 mm)

8SB 501 403-802

(1) Main mirror: 24 V, electrical adjustment, heated, curved radius 1800 mm

(2) Combined mirror (entry and rear-end observation mirror): manual adjustment, 24 V, heated, curved radius 200 mm

(3) Wide-angle mirror: manual adjustment, 24 V, heated, curved radius 300 mm

Spare parts and the complete Hella mirror range can be found in the Hella mirror brochure or in the Hella Electrics Catalogue 2007/2008

Mini relays

Relay without bracket – S2

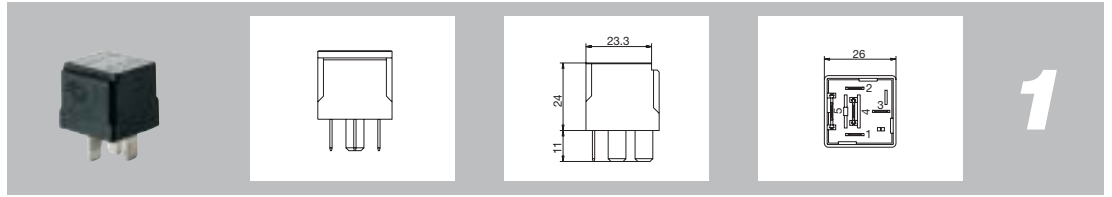

Relay with bracket – S2

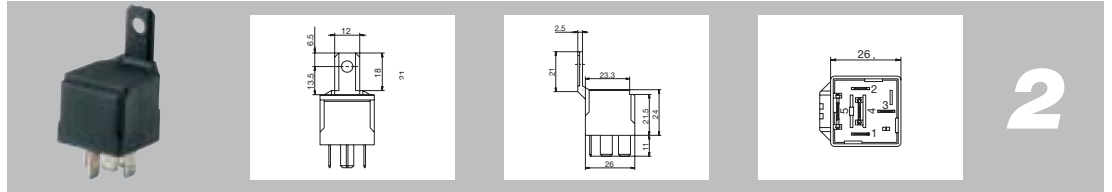

Relay without bracket – S1

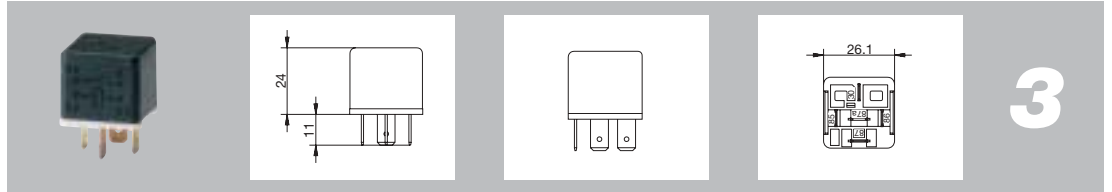

Relay with bracket – S1

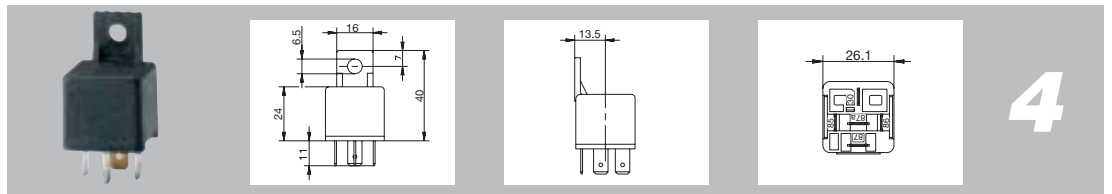

Special relays

Mini relay with blade-type fuse insert

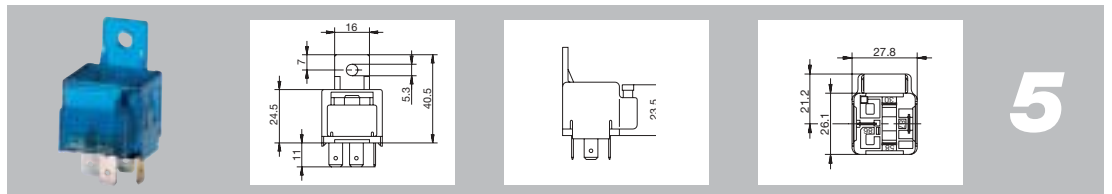

High-performance closing relay/battery disconnect relay

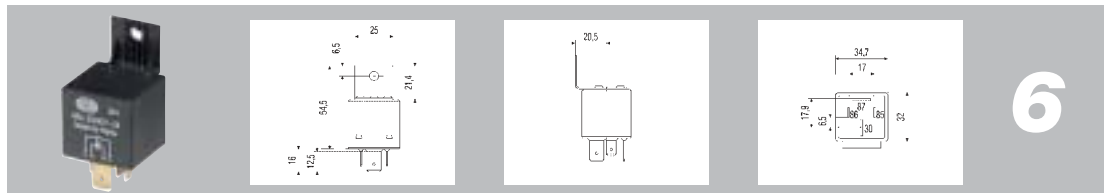

Skirted relay

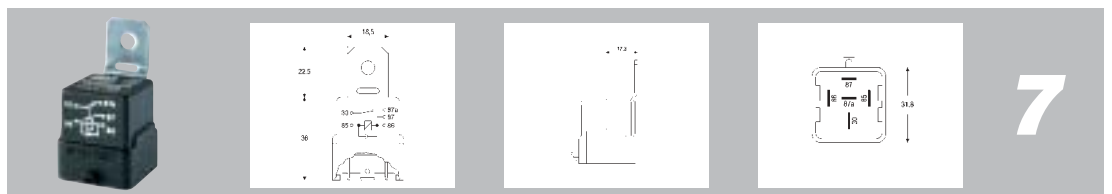

Plug matrices

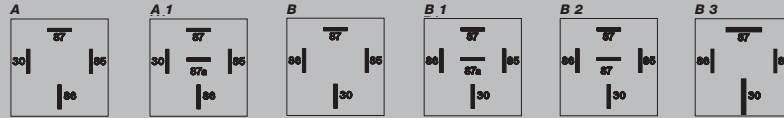

Switching matrices

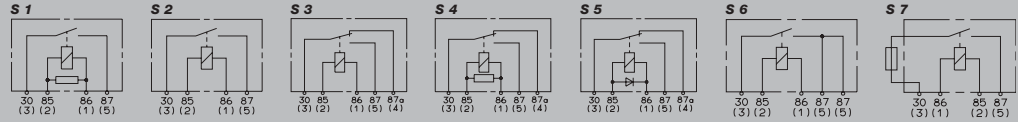

Plug matrices acc. to ISO 7588 / Blade connectors acc. to ISO 8092

Contacts

Current appl. (A)	Ohmic load				Inductive load				Light load				Simplified drawing	Plug matrix	Switching matrix	Coil resistance	Parallel resistance	Parallel diode	Contact resistance	Pack.	Part number
	Make contact (87)		Break contact (87a)		Make contact (87)		Break contact (87a)		Make contact (87)		Break contact (87a)										
	Nominal switching current (A)	No. of switchings (thous.)	Nominal switching current (A)	No. of switchings (thous.)	Nominal switching current (A)	No. of switchings (thous.)	Nominal switching current (A)	No. of switchings (thous.)	Nominal switching current (A)	No. of switchings (thous.)	Nominal switching current (A)	No. of switchings (thous.)				Ohm	Ohm	1N 4005	mV / 10A		
24 V																					
40	20	150	-	-	16	250	-	-	16	150	-	-	1	B	S1	305	1200	-	50	E	4RA 007 957-001
40	20	150	-	-	16	250	-	-	16	150	-	-	2	B	S1	305	1200	-	50	E	4RA 007 957-011
30	20	150	-	-	16	100	-	-	8	100	-	-	4	A	S2	315	-	-	50	E	4RA 003 510-091
30	20	150	-	-	16	100	-	-	8	100	-	-	3	B2	S6	315	-	-	50	E	4RA 003 510-141
30	20	150	-	-	16	100	-	-	8	100	-	-	3	B	S2	315	-	-	50	E	4RA 003 510-151
60	60	100	-	-	40	100	-	-	25	50	-	-	6	B	S2	310	-	-	50	E	4RA 003 437-091
60	60	100	-	-	40	100	-	-	25	50	-	-	6	B	S2	310	-	-	50	I	4RA 003 437-097
15	15	100	-	-	15	100	-	-	16	100	-	-	5	A	S7	315	-	-	120	E	4RA 003 510-651

Wechsler

Current appl. (A)	Ohmic load				Inductive load				Light load				Simplified drawing	Plug matrix	Switching matrix	Coil resistance	Parallel resistance	Parallel diode	Contact resistance	Pack.	Part number
	Make contact (87)		Break contact (87a)		Make contact (87)		Break contact (87a)		Make contact (87)		Break contact (87a)										
	Nominal switching current (A)	No. of switchings (thous.)	Nominal switching current (A)	No. of switchings (thous.)	Nominal switching current (A)	No. of switchings (thous.)	Nominal switching current (A)	No. of switchings (thous.)	Nominal switching current (A)	No. of switchings (thous.)	Nominal switching current (A)	No. of switchings (thous.)				Ohm	Ohm	1N 4005	mV / 10A		
24 V																					
40/20	20	150	10	150	16	250	8	250	16	150	5	100	1	B1	S4	305	1200	-	80 / 100	E	4RD 007 903-001
40/20	20	150	10	150	16	250	8	250	16	150	5	100	2	B1	S4	305	1200	-	50 / 80	E	4RD 007 903-011
30/15	20	100	10	100	16	100	8	100	16	100	3	100	4	B1	S3	315	-	-	50 / 80	E	4RD 003 520-091
30/15	20	100	10	100	16	100	8	100	16	100	3	100	3	B1	S3	315	-	-	50 / 80	E	4RD 003 520-071
30/15	20	100	10	100	16	100	8	100	16	100	3	100	3	B1	S5	315	-	X	50 / 80	E	4RD 003 520-151
30/15	20	100	10	100	16	100	8	100	16	100	3	100	3	B1	S4	315	1200	-	90 / 80	E	4RD 003 520-221
Skirted 24 V																					
10/20	20	100	10	100	16	100	8	100	16	100	3	100	6	B1	S5	320	-	X	100	E	4RD 930 141-141*

E = Individual packaging I = Industrial packaging

* splashwater-proof in the plug area in connection with receptacle housing **8JD 745 803-001**

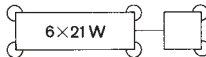
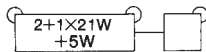
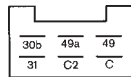

Flasher unit

Single-circuit flasher unit, direction indicator and hazard warning lights, 24 V, 6-pin

2+1(6) x 21 W **4DM 003 944-041**

3+1(8) x 21 W **4DW 003 944-051**

2+1(6) x 21 W **4DM 006 475-051**

3+1(8) x 21 W **4DM 006 475-071**

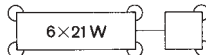
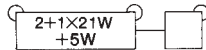
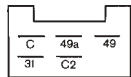

Flasher unit

24 V, 5-pin

4DM 003 474-001

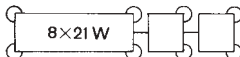
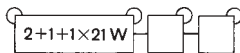
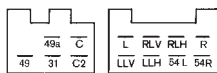

Triple-circuit flasher unit

Direction indicator and hazard warning lights, 24 V, 13-pin

4DN 004 589-031

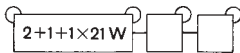
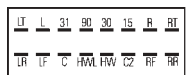

Flasher unit

24 V, 2+1+1(8) x 21 W

4DN 007 431-021

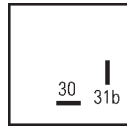

Buzzer

2 blade terminal connections, 6.3 mm with bracket

24 V

3SB 003 985-021

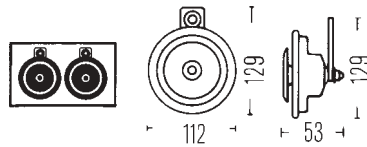

Signal horn B36

Galvanised metal housing, black membrane

power consumption: 72 W, noise level: 116 dB(A)

24 V, 335 Hz

3BA 002 768-382

24 V, 400 Hz

3BA 002 768-431

with Teflon pellet as humidity protection

24 V, 400 Hz

3BA 002 768-201

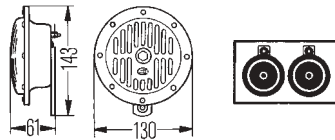

Supertone horn DL50

Metal housing, painted black, protective grid,

power consumption: 60 W, noise level: 114 dB(A)

24 V, 310 Hz

3CA 004 811-021

24 V, 380 Hz

3CA 004 811-031

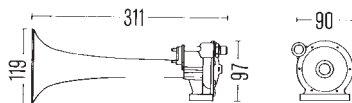

Pneumatic fanfare

for vehicles with pneumatic brake, housing made of sturdy

die-cast metal, black plastic bell mouth, compressed air

range: 6 – 8.3 bar, power consumption: 50 W, noise level:

118 dB(A), 24 V, 400 Hz, suitable for 10 mm compressed

air hose

3PA 004 206-011

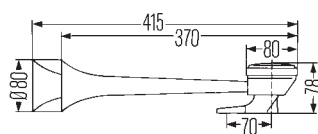

Pneumatic fanfare

for vehicles with pneumatic braking system, with 2 chrome-

plated trumpets, compressed air range: 4 – 8.5 bar, noise

level: 118 dB(A), operation either via pull valve (9XL 715

989-01), foot valve (9XL 715 990-001)

or

electro-valve (9XL 715 991-001), these must be ordered

separately, type approval **E3** 42 926 **e3**

Compressor 2-tone fanfare set Highway 24 V, 300/320 Hz

3PB 005 411-001



Socket

7-contact to ISO 1724, plastic version,
screw terminals

12 V

8JB 001 943-003



Socket

13-contact to ISO 11 446, plastic version,
screw terminals,
with rubber grommet and rubber seal in cover

12 V

8JB 005 949-001

12 V, with rear fog light switch-off

8JB 005 949-011



Miniature short adapter

from 7-contact socket (ISO 1724) on towing vehicle
to 13-pin plug (ISO 11 446) on trailer

12 V

8JA 008 981-001



Socket

2-contact acc. to ISO 4165, with spring-loaded cover,
6,3 mm blade terminal connections, load capacity: max. 16 A

6-24 V

8JB 001 946-082



Power socket

2-contact with cover and clamping sleeve,
suitable for cigarette lighter plug,
6,3 mm blade terminal connections,
load capacity: max. 16 A

6-24 V

8JB 008 023-001



Universal plug

2-contact with screwed strain relief and 8 A fuse, suitable for cigarette lighter and standard sockets (ISO 4165), screw connection up to 2.5 mm²

6–24 V

8JA 007 589-001



Plug

2-contact acc. to ISO 4165

6–24 V

8JA 002 262-001

Trailer connection device



Allows the use of 12 V trailers on buses with 24 V operating voltage without having to use a separate load compensation device.

Possible types of installation: ■ on the towing vehicle (12 V socket)
■ on the trailer
■ or between the two vehicles

Possible areas of use: ■ as a bicycle trailer
■ ski trailer
■ luggage trailer



Additional installation of trailer control lamps is not necessary since this function is carried out by the C2 control of the existing flasher unit.

Universal connection device

with low installation and cabling expenditure

5DS 008 125-011

Voltage reduction and load compensation devices

In some vehicles with an on-board voltage of 24 V it is often necessary to reduce the voltage to 12 V in order to be able to install various devices, such as radios or radio transmission and receiving sets, for example. Hella has a range of voltage reduction devices with different loads available: permanent current 2 A, 4 A or 8 A over the whole range of voltage and temperature. To select the right voltage reduction device, simply add the current consumption of the consumers together and you will have the power you need.



Voltage reduction device 2 A

8ES 006 658-001

Technical details:

Input voltage: 18 V–30 V
Output voltage: 14 V +/- 3 %
Output power: 28 W
Dimensions: 100 x 97 x 27 mm

Voltage reduction device 4 A

8ES 006 658-011

Technical details:

Input voltage: 18 V–30 V
Output voltage: 14 V +/- 3 %
Output power: 56 W
Dimensions: 125 x 65 x 125 mm

Voltage reduction device 8 A

8ES 006 658-021

Technical details:

Input voltage: 18 V–30 V
Output voltage: 14 V +/- 3 %
Output power: 112 W
Dimensions: 250 x 65 x 125 mm

Hella load compensation devices

A load compensation device determines the voltages of the two 12 V batteries. If the ground-side battery should show less voltage, the load compensation device provides compensation current. An LED indicates when the device is working.

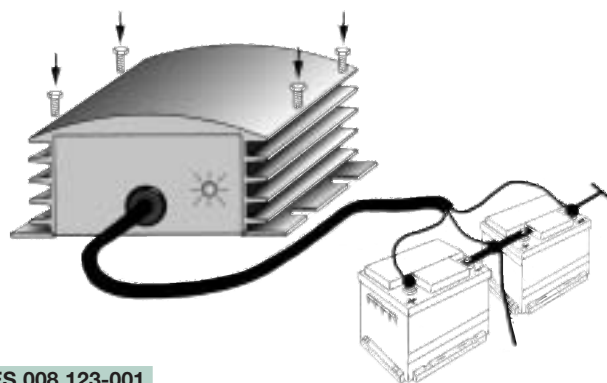

Load compensation device "Plus"

8ES 008 124-001

Technical details:

Rated voltage: 24 V
Compensation current: 8 A
Switch-on voltage: 27 V
Switch-off difference: 0,5 V
Operating temperature: -25 °C to +65 °C
 Inverse polarity protection and short-circuit-proofness
Protective rating: IP 5K9K

Load compensation device

8ES 008 123-001

Technical details:

Rated voltage: 24 V
Compensation current: 5 A
Switch-on voltage: 27 V
Switch-off difference: 0,5 V
Operating temperature: -25 °C to +65 °C
 Inverse polarity protection and short-circuit-proofness
Protective rating: IP 5K9K



© Hella KGaA Hueck & Co., Lippstadt 922 999 125-924 SCH/09.07/2.4 Printed in Germany
Hella KGaA Hueck & Co. Tel.: +49 (0) 29 41/38-0
Rixbecker Straße 75 Fax: +49 (0) 29 41/38-71 33
59552 Lippstadt/Germany Internet: www.hella.com



**Ideas today for
the cars of tomorrow**



© Hella KGaA Hueck & Co., Lippstadt 922 999 125-925 SCH/09.07/1.0 Printed in Germany

Hella Limited

Wildmere Industrial Estate
Banbury, Oxon OX16 3JU
Tel.: (0 12 95) 27 22 33
Telefax: 0800 783 2571
e-mail: hella.ltd@hella.com
Internet: www.hella.co.uk

Hella Ireland Limited

Woodford Business Park
Santry, Dublin 17
Republic of Ireland
Tel.: +353 (1) 8 62 00 00
Telefax: +353 (1) 8 62 11 33
e-mail: irlsales@hella.com
Internet: www.hella.ie



**Ideas today for
the cars of tomorrow**



© Hella KGaA Hueck & Co., Lippstadt 922 999 125-926 SCH/09.07/0.5 Printed in Germany

Hella, Inc.

201 Kelly Drive,
P.O. Box 2665
Peachtree City, GA 30269

Toll Free: 1-877-224-3552

Fax: 1-800-631-7575

www.hellausa.com



***Ideas today for
the cars of tomorrow***